

**Policies and tools for catchment  
management of water resources: Field  
management, tradable permits and  
stakeholder participation**

Dennis Collentine  
*Department of Economics  
Uppsala*

**Doctoral thesis  
Swedish University of Agricultural Sciences  
Uppsala 2003**

**Acta Universitatis Agriculturae Sueciae**  
Agraria 433

ISSN 1401-6249  
ISBN 91-576-6476-5  
© 2003 Dennis Collentine, Uppsala  
Tryck: SLU Service/Repro, Uppsala 2003

# Abstract

Dennis Collentine, 2003. *Policies and tools for catchment management of water resources: Field management, tradable permits and stakeholder participation.*

Doctoral Thesis.

ISSN 1401-6249, ISBN 91-576-6476-5

This dissertation is a set of related articles. The five articles deal with alternative tools and policies for addressing water quality management. The focus of the dissertation is on management decisions of three groups at the catchment level: farmers, other stakeholders and catchment authorities.

The first two articles address how field management decisions are made by farmers. The first of these two articles presents a linear cost method for calculating the economic impact of adopting particular 'best management practices' (BMPs) on individual fields. The second article describes how decision heuristics may be used by farmers for making management choices within a framework of bounded rationality. This article presents a decision support system (DSS) that has been developed for evaluation of best management practices (BMPs). The model presented here, called LENNART, is a net-based interactive database that combines a natural science model, SOILNDB, with the linear cost method developed in the first article for the evaluation of BMPs. The model works with heuristics to support BMP implementation decisions by farmers.

The second two articles take up the application of tradable discharge permit (TDP) policy to reduce nutrient losses from farmland from non-point sources (NPS) of pollution. The first of these two articles is reactive. This article surveys the status of discharge trading programs and concludes that the lack of success of these programs is due to design problems, specifically the lack of well-defined property rights to the discharges. The second article is proactive and describes how a composite market system for TDP may be designed to fulfil its primary purpose, the cost effective abatement of nutrient discharges.

The fifth article describes a method for structuring stakeholder participation in the management of water resources at the catchment level. The model described in this article, CATCH, builds on the use of the principles of discourse and deliberation to define sets of socio-economic parameters for the evaluation of management plans.

*Key words:* information costs, transaction costs.

*Author's address:* Department of Economics, Swedish University of Agricultural Sciences, Box 7013, S-750 07 UPPSALA, SWEDEN.

e-mail: [dennis.collentine@ekon.slu.se](mailto:dennis.collentine@ekon.slu.se)

*To Yvonne and our children Josef, Anton, Linus and Gabriel.*

## Preface

This thesis is about water. A subject which I knew little about other than through my experience as an enthusiastic user, prior to my participation in the Swedish Water Management Research Program (VASTRA). I have been given the opportunity over the last four and a half years to learn not only a lot about water but also to work within an area where the academic community participates actively with the community outside the ivory towers. This particular aspect has been important to the development of my work.

On a personal level, economic theory for me has always been a way to interpret the world around me. Theory is interesting in that it allows me to see events from an abstract perspective. Being a relatively inquisitive person, I like to ask a lot of questions, applying economic theory gives me an opportunity to indulge my curiosity about the world and hopefully develop some insight about what I see. The thesis that follows is an expression of that curiosity and hopefully communicates some of that insight

This thesis owes a great deal to great number of people. Since it is customary in books to have a preface that is shorter than the work that follows, this necessarily limits the acknowledgement of people and events that have contributed to this thesis. On a social plane there are numerous family members and friends that have provided me with inspiration and support. Though your names don't appear below this is not reflective of your importance to me, thanks. This is also true for many of the people I have had the pleasure of sharing a common workplace with over the years. What I would like to do in the following paragraphs is single out a few of the people and their contributions that have had a direct impact on the development of this thesis.

I want to start by acknowledging two people from the University of Gävle where I have been employed for the past eight years. First the person who made it possible for me to be offered a tenured position in the Department of Economics at Gävle and then who later saw to it that I left the department to work on my doctoral degree, Apostolos Bantekas. While Apostolos is greatly responsible for getting me started on this dissertation the contribution of another colleague, Mats Landström, has allowed me to finish it. Mats took over a course that I was scheduled to teach at the same time that I needed to make the last minute adjustments and format the thesis before turning it over to the printer. The fact that you are reading these lines is in part attributable to Mats' help.

However, the greatest impact on the content of the thesis has come from people that have been associated with the VASTRA research program. Some of their names appear on two of the articles included in the thesis but there are other names that do not. Hans Bertil Wittgren, the program director for VASTRA during the first phase of the program, provided support for the development of the DSS LENNART that is the focus of the first two articles in the thesis. He not only gave his encouragement and support for the model conceptually but in his role as program director he also made funding available that made possible the development of the prototype described in these articles. In addition, Hans Bertil

and Lars Anders Hansson's enthusiasm for the model CATCH led to continued work with the ideas behind this model and the fifth article in this thesis. The current program director of VASTRA, Anna Jöborn, has followed development of all three models described in the thesis with interest and promoted support for these models both within the program and through contact with potential users. Although there are many other people within the present VASTRA program as well as those that have been involved with VASTRA in the past that could be acknowledged here, there are a few people I'd like to single out.

During Phase I of the VASTRA program one of the tasks of the sub-program I worked with was the development of an integrated decision support tool for nutrient management. In particular, a model which would combine three sub-models: a bio-physical agronomic model of root-zone movements of nitrogen, a distributed hydrological model of groundwater flows and an economic model of the farm level and social costs of best management practices (BMP). After initial attempts by the entire sub-group of researchers (10-15) to identify these models and what they would do, the task devolved to a group of three people.

Martin Larsson from the Department of Soil Sciences (Water Quality Management) at the Swedish University of Agricultural Sciences (SLU) was one of these people. Martin brought many positive qualities with him which made it possible to accomplish the task set out for us; he was a hydrologist by training, worked within the department that was developing a model for characterizing nitrogen leaching from agricultural practices, had worked with other model development, was a farmer and lastly was not only able to work effectively with others but could laugh easily as well. The second person was Nils Hannerz, at the start of our cooperation a VASTRA doctoral student at the Division of Land and Water Resources at the Royal Institute of Technology (KTH). While Nils was employed at the Royal Institute to work with groundwater modelling his passion was systems analysis, an interest that he found an outlet for in the work to design a decision support system (DSS) for nutrient management. Nils left his position at KTH and after a stint in Gothenburg working as a freelancer started working as a research assistant at the Swedish Institute of Agricultural and Environmental Engineering (JTI) in Uppsala. Nils brought with him not only his analytical sensibilities, familiarity with hydrology and computer programming skills but also a lot of enthusiasm. An enthusiasm that included working with practical solutions and applications as well as for new ideas. I was the third member of the group, the economist.

The three of us worked together over a period of two years to develop the prototype of the DSS LENNART. The model evolved as a combination of interests and expertise but I think primarily as a result of the ability of both Martin and Nils to not only listen to each other (and put up with me) but also the congeniality that was always present in our discussions. During this time we not only developed a model but also a friendship.

There are a couple of other people that should be mentioned in connection with development of the model LENNART. Hans Bertil Wittgren was already named above, however there is another person whose contribution I would like to acknowledge here: Holger Johnsson also at the Department of Soil Sciences

(Water Quality Management) at the Swedish University of Agricultural Sciences (SLU). Holger, who developed the SOILN/SOILNDB models that are used in LENNART to estimate nitrate leaching, sat in on many of the planning meetings with Martin, Nils and myself where his support, encouragement and suggestions were all positive contributions to our work.

I also want to name here several VASTRA doctoral colleagues with whom I've worked and who are all co-authors to the fifth article in the thesis. The idea that led to the CATCH model described in this article evolved out of a doctoral course workshop sponsored by VASTRA. Three of the other participants in the workshop continued to work with the idea; Annika Ståhl-Delbanco, Sofia Kallner Bastviken and Åsa Forsman. A fourth VASTRA doctoral candidate, Victor Galaz got involved in the project later on. While Åsa went on to work in other areas after finishing her doctorate, the remaining four of us have continued to work with the model and promote its application as a method for involving stakeholders in catchment area management.

In addition, among my many colleagues at the Department of Economics at the Swedish University of Agricultural Sciences (SLU) there a couple people who I would like to single out by name. Rob Hart served as the opponent at my final seminar where he waded through all the work presented in this thesis. The logic and scientific merit of the unpublished pieces of the thesis were all improved due to his comments. Over the period that I have worked at the department I have presented various parts of the material in this thesis at seminars. While the number of participants at these seminars has not been extensive (an understatement), there has been one person that has consistently participated, Ficare Zehaie. I would like to think that it was the quality of the presentations that brought Ficare back time after time but I think it really reflects his intrinsic respect for other people and their ideas.

Two other people at the department that I want to acknowledge are Clas Eriksson and Christina Brundin. The door to Clas's office is always open. I've gone there more than once and gotten help with something. These 'somethings' can be found here and there in the thesis articles. When I look around my office as I write these final lines in my thesis I see the piles and stacks of papers that I need to spend some time sorting and cataloguing after I finish. These piles represent a lot of the background for the thesis. They are copies of articles and chapters that I've used to position the research and to develop ideas. Christina, the librarian here at the department, has first searched out and then painstakingly made copy after copy after all my requests and then delivered these to my mailbox. This has allowed me to spend less time searching and copying and more time thinking and communicating.

Finally, and that was a long time getting to this word, there is one more very important person whose support was always present, my adviser Lars Drake. It's often difficult to identify what particular support is most critical in the development of ideas. This is the case with Lars Drake's involvement in the evolution of not only the model LENNART but also with the other ideas presented in this thesis. What Lars provided from the start of our involvement was respect and as a direct result of that respect, freedom. This was important to me as it

allowed me to work on ideas that I felt were important and to follow through with these ideas. I think in retrospect that I could have been clearer in communicating to others the ideas that are represented in this thesis, but I could blame this in part on the fact that it has always been easy to communicate them to Lars. I've never felt that any suggestions that I came with were ever negatively met by Lars but rather that I always came away from our discussions with both more enthusiasm as well as a few good suggestions for improvements. Since Lars has always been pleased to discover instances when I use the English language improperly I've included this last one for him.

Dennis Collentine,  
Uppsala, October 2003.



# Contents

## **1. Introduction, 11**

- 1.1. Why catchment management?, 12
  - Availability and water management, 13*
  - Allocation conflicts in a catchment area, 16*
- 1.2. Catchment decision arenas, 18

## **2. Tools and policies for water quality management, 19**

- 2.1. Agri-environmental programs, 21
  - Evaluation of BMPs, 23*
  - Information costs, spatial scale and decision heuristics, 25*
- 2.2. Decision support for field management, 27
  - Bounded rationality and the use of heuristics, 28*
  - Net based platform for a DSS, 30*
- 2.3. A market for tradable discharge permits, 31
  - Composite market model for TDP, 32*
  - Property rights, 34*
  - Transaction costs, 34*
- 2.4. Stakeholder participation in catchment management, 35

## **3. Conclusions, 37**

*Further research, 40*

## **References, 41**

## **Article I – V**

## Articles appended to the thesis

This thesis is based on the following articles by Dennis Collentine except where otherwise stated.

- I. Collentine, D. (manuscript). Economic modeling of Best Management Practices (BMPs) at the farm level.
- II. Collentine, D., M. Larsson and N. Hannerz, (manuscript). Exploiting decision heuristics and IT in the design of a DSS for voluntary agri-environmental programs. Accepted for publication in *Ecological Economics*.
- III. Collentine, D., (2002). Search for the Northwest Passage: The assignation of NSP (Non-point source pollution) rights in nutrient trading programs. *Water Science and Technology*, 45(9): 227-234.
- IV. Collentine, D., (manuscript). Composite market design of a Transferable Discharge Permit (TDP) system for water quality management. Submitted to the *Journal of the American Water Resources Association*.
- V. Collentine, D., Å. Forsman, V. Galaz, S. Kallner Bastviken and A. Ståhl-Delbanco, (2002). CATCH: decision support for stakeholders in catchment areas. *Water Policy*, 4: 447-463.

Papers III and V are reproduced by permission of International Water Association (IWA) Publishing.

# 1. Introduction

*“When all you have is a hammer – everything starts looking like nails.”*

Chris Barnes, systems analyst, Australian National University, at the conference: Agricultural Effects on Ground and Surface Water, Oct. 1-4, 2000, Wageningen, Holland.

The research presented in this thesis is about choices in a real world full of time constraints, partial (asymmetric) information, site-specific physical parameters and individual values. The environmental problems that are at the heart of water quality problems are the effects that human activities have on water quality. The main focus of the research is on how choices are made which have an impact on water quality. One part of the research is aimed at techniques for evaluating the costs of adopting better water quality management practices on the farm. A second part of the research is about the design of environmental policy that reduces information costs for polluters making investment abatement decisions that will reduce the flows of nutrients from land use. The third part of the research deals with how stakeholders in a catchment area can participate in water quality management choices.

The research was performed as a part of a Swedish national research program for water management (VASTRA). The goal of the program defined at the inception of the first three-year phase (VASTRA, 1998, p.1) was “to develop catchment-based water management strategies that are sustainable from ecological, economical and social perspectives”. One of the partial goals identified in the program plan (VASTRA, 1998, p.11) was to arrive at a state “where individual actors, or groups of cooperating actors, have the tools and incentives to plan and take measures that are economically and environmentally sound in terms of management of nutrient fluxes”. To achieve these goals the research program supported and coordinated a multi-disciplinary approach to the development of management tools. The models presented in this thesis are part of the outcome of the program and that approach.

Natural science models describe environment effects; economic models describe the human decision environments that lead to the effects. One of the models described in the thesis is a combination of a biophysical process model of the root-zone area of cultivated fields and an economic behavioral model. The product of this combination is a decision support system, a model for field management of nutrients. A second model in the thesis suggests how biophysical nutrient transport models can be used to establish limited property rights which in turn make it possible to create markets for transferable discharge permits based on those rights. The primary goal of the third thesis model is to determine a set of socio-economic parameters and biophysical indicators for a particular catchment that reflects stakeholder preferences based on site-specific characteristics.

As a national research program, the focus of VASTRA has been on the search for solutions to water quality problems in Sweden. Descriptions of water quality problems, in particular eutrophication, and the alternative abatement measures that

are used to develop and illustrate the models reflect current conditions in Sweden. A subsidy program for the cultivation of catch crops supported by the Swedish Board of Agriculture was used to analyze farmers' decision to adopt best management practices and serves as the prototype in the decision support system developed as a result of that analysis. A eutrophic system of lakes in southern Sweden was used to illustrate how a catchment based model for stakeholder participation could be used to evaluate alternative abatement measures. Although the models were developed primarily to address water quality problems in Sweden, the principles are universally applicable. Each of the models may be adapted for use in other environments through changes in content while maintaining the basic model structure.

The purpose of the thesis is to explore how analysis of individual choices and preferences may be used to support decisions in the management of water resources. The three models presented in the thesis are the result of that analysis. Two of the models are decision support systems (DSS) that work within the constraints of present policy. These two models are tools. The first is a field management tool for supporting choices by farmers. The second is a tool to support the inclusion of stakeholder preferences in water management through participation in the decision-making process. The third model is a policy proposal for a transferable discharge permit (TDP) program design that specifically addresses choices made by agricultural producers as well as other non-point sources (NPS) of pollution. A unifying factor is that all three models are designed for use in the management of water resources at a catchment level. Why at a catchment level? What is it that makes catchments an appropriate level for development of management models? This is the question discussed in the first section below. In addition, each of the models targets a particular set of decision makers at the catchment level. These decision environments are discussed in the second section below. The final section describes the three models, summarizes the research and discusses the possible extensions and applications of the models.

## **1.1 Why catchment management?**

From a natural science perspective, the argument that catchment areas are the appropriate level for water management is easy to accept. The catchment serves as the organizational unit for spatial surface water flows including the interface between groundwater and surface water.<sup>1</sup> However, present socio-political structures have not been designed with catchment boundaries as an organizing principle. Therefore for social scientists the arguments for catchment based management are weaker. The argument made by the US EPA Office of Water (EPA, 1996) is representative of the reasoning usually found for watershed management from a socio-political perspective: "Watershed protection can also

---

<sup>1</sup> Although groundwater is not organized in catchment areas, application of the ideas presented here are equally applicable to water management based spatially on aquifers. The discussions in this section assume that groundwater is subject to catchment management, an assumption that also corresponds to the management principles of the EU Water Directive as well.

lead to greater awareness and support from the public. Once individuals become aware of and interested in their watershed, they often become more involved in decision-making as well as hands-on protection and restoration efforts. Through such involvement, watershed approaches build a sense of community, help reduce conflicts, increase commitment to the actions necessary to meet environmental goals, and ultimately, improve the likelihood of success for environmental programs.”

While the results of involvement are clear what appears to be missing are reasons beyond altruism for generating this interest. Factors which may help to understand the motivation behind the presumed interest are important to understand as there seems to be a general consensus that stakeholder involvement will be the guiding principle for catchment level management (NRC 1996, WWF 2001, O’Neil and Spash 2000)).

#### *Availability and water management*

In order to explore why catchment areas are the appropriate level for defining boundaries for water management it is important to start with a description of the resource being managed. Water is not a homogenous resource. Water is a collective term for a variety of resources with similar properties. Water resources are of varying quality as well as unevenly spatially distributed. Some types of water are appropriate for some uses while other types may be appropriate for other uses. These uses are the services provided by that particular resource, in this case by a particular type of water quality.<sup>2</sup> Table 1 lists examples of service categories provided by water. Not all these services need to be, or can be, provided by one type of water quality. For example, if the service provided is recreational boating the water quality required to provide this service is relatively low. Although ambient properties may be of importance as well and indeed increase the quality of recreation, the primary requirement refers to volume rather than quality. Water quality requirements for human consumption, on the other hand, are rather narrowly defined and regarded as high quality. Table 1 includes a list of quality demands for the services described; the range is from the highest quality, narrowest definition, to the lowest quality, the broadest definition.

There are some water quality types that can serve a wide variety of uses, while others are more use specific. For example, drinking water may be used for a wide variety of services that may not require that particular quality (irrigation, waste treatment, etc) but which is completely satisfactory if used for these purposes. However, if the service being provided is a specific environment that supports a specific aquatic biotope then perhaps drinking water quality may not be able to provide this service. In addition, while drinking water quality may be satisfactory for recreational boating the reverse doesn’t hold. The degree to which the water quality demanded for a specific service can support a range of other services is described in Table 1 as the inclusivity of that service. If the quality can only support a narrow range of services then this is categorized as a less inclusive class.

---

<sup>2</sup> See Bergstrom *et al* 2001 or NRC 1997 for elaboration of the concept of service flows as the basis for valuation.

It should be noted here that this designation is not intended to serve as a proper classification based on theory but rather as an *ad hoc* indicator that describes an important characteristic. This characteristic is of interest in the discussions about the conflict over allocation of water classes for the provision of services in a catchment, the central theme of this section. Water management is therefore about the allocation of water quality to provide desired services. The next step to analyze is what is meant by water quality allocation.

**Table 1.** Surface water service flows, related quality demand and exclusivity/inclusivity of usage. (Adapted from NRC 1997)

<b>Type of service flow</b>	<b>Quality</b>	<b>Inclusivity</b>
Drinking water	High quality	Inclusive, broad range of applicability
Irrigation	Low quality, some non-biological contaminants may be a problem	Inclusive for uses where quality is not critical
Non-irrigation agricultural use	High quality for livestock	Similar to drinking water, but less inclusive
Manufacturing of food products	High quality	As for drinking water
Manufacturing of non-food products	Low quality	Inclusive for services where volume not quality is important
Power production	Low quality for hydro, higher quality for cooling use	Similar to non-food manufacturing
Waste treatment	Low quality	Similar to non-food manufacturing
Recreational swimming	Less than drinking water quality, ambient quality important	Broad range of uses, less inclusive than drinking water
Recreational boating	Less demanding than swimming quality	Volume most important
Fishing	Must be able to support desired aquatic life	May be used for all uses where volume is the primary factor
Biotope support	Must be appropriate for the particular biotope	Inclusive for all volume uses, may be used for higher quality services as well

Allocation of a resource is the distribution of measurable quantities of a particular good. The allocation of water, what is commonly described as water management, is the allocation of classes of water quality to support services. The allocation of water is making available a quantity of an appropriate quality of water for that particular service. As noted above, due to the fact that the

classification of availability is based on the services that can be provided availability may be multi-purpose, i.e. broadly inclusive. For example, drinking water quality made available for household consumption may be used for human consumption or for services, which could be provided by a lower grade of water quality, such as that needed for sanitation or lawn maintenance purposes. However, availability may also be single purpose, narrowly inclusive. An example of this is water that provides a service to a particular biotope may not be able to provide that service if it is diverted to other services. Availability is a description of a particular water allocation based on the services, which that allocation provides, an allocation which is limited by the capacity of the system.<sup>3</sup>

A change in allocation related to volumes and qualities is a change in the state of availability. Availability can therefore be regarded as a state variable, a variable, which describes a particular arrangement of availability for a single class of water quality or for a combination of water quality classes. Spatially, availability may be used to describe the allocation of water quality classes in a catchment area. Temporally, availability depends on flows. In addition to flow variation, changes in this state variable may also be due to changes in factors which control the level of the state variable, either through increases or decreases in capacity for the provision of services and/or reallocation of the flows between services. Increases in capacity may also be described as investment decisions where the cost of investment is the capital investment needed to increase capacity for that service.<sup>4</sup>

**Figure 1.** Valuation of water services

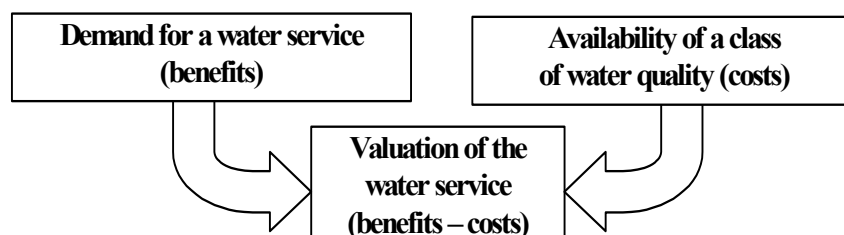

Availability of a water quality type provides value to the users of the services that this state makes possible. The value is not in the water but in the service, which the water provides (Figure 1). A particular state of availability can be described by the aggregated value of the services provided by that state. The value

<sup>3</sup> Capacity may also serve to describe the state of availability. However, the total sum of availability must always be less than or equal to total capacity and increases in capacity may not always lead to a reallocation of availability. Thus, the correspondence is not exact and although each of these concepts may be of use jointly to describe conflict resolution, for expository purposes they are considered separately.

<sup>4</sup> Adaman and Devine (2001) describe this type of activity, increased capacity, as a result of market forces as distinct from market exchange.

is the difference between the benefits generated by the service and the costs of providing the service. The costs are the direct costs associated with the production of the service as well as the indirect costs (opportunity costs), which this particular use generates. The benefits are aggregates derived from individual benefits, the value of the service to users of the service. A recent study on the economic value of water (Bergstrom et al, 2001) describes the source of value which gives rise to the benefits, as follows (p.10):

" ... the economic value of water quality to individual  $j$  is influenced by the socioeconomic characteristics of individual  $j$ . These socioeconomic characteristics include indicators of tastes and preferences such as age and education, and indicators of environmental and public good attitudes such as the priorities an individual places on public provision of various goods and services."

However, since many of these services have the nature of public goods or other non-market values aggregation may be impractical (costly) or impossible (indivisible).<sup>5</sup> An alternative method is to treat the values generated by these services as social costs and benefits. Instead of the value being an aggregation of individual values driven by the "socioeconomic characteristics of the individual", these characteristics can be aggregated and values derived from the socioeconomic characteristics of the aggregated individuals, the social community. Using this method, the value of the state variable availability is driven by a set of socioeconomic parameters of the community that reflects the costs and benefits of water management strategies for the provision of services (allocation of water quality) to that community. The common denominator for this community is that they derive value from the services provided by the same class of water; this also serves to define an interest group associated with that service.

#### *Allocation conflicts in a catchment area*

Conflict over use of a resource presumes that the resource in question is shared, that is, in the framework of the discussion presented above that it may be used to provide alternative services. The more inclusive the water quality class, the more alternative services that may be in conflict over allocation of that class of water. Allocation of availability assigns values to the services provided (as in Figure 1). Changes in the state variable availability are a reassignment of value and can be described by the costs and benefits attached to the reassignment. Following the flows described in Figure 1, the reassignment is a change in availability and there are costs associated with that change. However, the reassignment must be driven by the benefits that accrue to users of the services.

All volumes of all types of water quality are being used at every point in time in each state to support a flow of services. The present state of availability represents a dynamic tension between conflicting interests over the allocation of water classes, the services provided and the net value (costs and benefits) derived from

---

<sup>5</sup> Valuation techniques such as contingent valuation are commonly used to estimate these aggregate values, see Söderholm (2001) for a critical comparison of using this valuation technique and valuation derived from using deliberative methods.



those services. There are no surpluses to be allocated, therefore any change gives rise to changes in the costs and benefits derived from the services. Changes in availability are allocations of gains and losses to the users of the services that are affected by the change, the stakeholders. Conflicts in stakeholder interests in a catchment arise from the distribution of the gains and losses due to changes in the provision of (availability of) services.

For example, a higher volume of drinking water may be made available through infiltration, active water purification, prevention of a flow of contaminants, etc. Each of these measures, which are also control variables, changes the state of availability and has associated direct or indirect costs as well as benefits. If the demands for a service increase *ceteris paribus*, then the potential value for that service increases as a result of the increase in benefits and the change in net value depends on the costs of reallocating availability. For example, if the demand for drinking water in a catchment area increases due to an increase in population, the change in net value depends on the direct and indirect costs of increasing availability for that service. If the volume of drinking water increases through drilling new wells, the direct cost of the change in state would include the costs for drilling and distribution. Indirect cost may include among others, the decrease in the option value of the groundwater when it is no longer available as a reserve or the possible subsidence of structures due to the removal of groundwater locally. As another example, if the volume of water quality available for support for aquatic biotopes were to increase through the reduction of nutrients entering watercourses from farming practices, the direct costs would include any losses in farm income, while the benefits would accrue to stakeholders that derive value from the existence of the biotope. The benefits are always the aggregate gains to the stakeholders who derive value from the increase in the availability of water for that service. The changes in value are a redistribution of value among users of the associated services, which may be positive for some (benefits) and negative for some (costs). The net change is the social value of moving from one state to another, the value of the change in services.

Services provided by the availability of water quality are local in relation to the spatial location of the water type providing the service. Water provides a service where it is spatially located. Water in a lake provides a recreational boating service on that lake. The same water could provide a recreational boating service at another location only if it is transported to that location. Ignoring for the moment flows between locations (a waterway system), transport of sufficient volumes for an activity such as recreational boating is expensive due to the volumes that would need to be transported.<sup>6</sup> This is true in general; the human-induced movement of water flows in the volumes needed to provide services is costly. To justify this transport reallocation the benefits need to cover the cost of transportation as well as the costs due to the change in service flows. This is especially relevant when considering reallocation from one catchment area to another. Within a catchment area transport costs are less significant. Increases in availability upstream may be

---

<sup>6</sup> A dam could, for example, be built to provide boating services at another location within the catchment.

achieved by building dams; downstream availability may increase if drainage systems are constructed in upstream areas.

The aggregate value of a class of water as described above depends on availability. If availability were not constraining then that class of water would be expected to have a low value. In an area of abundant rainfall there is a high degree of availability for services such as watering lawns and the value from increases in availability, by increasing capacity for example, would be relatively low. The costs, in turn, for providing this service would have to be extremely low if there were an expectation for positive changes in net value for increasing capacity. Costs are a limiting factor for reallocation of water services. Within a catchment area geographical proximity lowers the costs of transportation associated with reallocation. In addition, movement within a catchment may also be possible through diversion at a lower cost than transport. Therefore within a catchment there is a potential for low cost provision of services and a potential for high net value for these services locally. Conversely, transport of services to areas outside of the catchment is associated with high costs and even though benefits may be large the net value is likely to be relatively low. Conflicts over allocation will be most pronounced where changes in net values from reallocation are the highest.

There are two reasons for management of water resources at the catchment level. Firstly, catchment areas are relevant for reallocation decisions because the greatest effects of reallocation, the highest changes in the social value of moving between states, will be local. The services provided by water have the highest value locally and thus any changes to these services will have the greatest impact locally. The concept of including stakeholders (the recipients of the service flows provided by availability) in reallocation decisions is in recognition of the fact that the current and presumptive stakeholders that incur the greatest changes in value will probably be found in the catchment area. Secondly, negative changes in water quality have their source in the catchment as well. There must be a surface of contact between the polluting generating activity and water in the catchment. Although it is the activity that creates the pollution, the contact surface allows the pollutant to degrade the water quality. Mitigation may be possible through either changes in the activity or changes in the contact surface; both of these take place within the catchment itself.

## **1.2 Catchment decision arenas**

Development of decision support systems (DSS) and policies for water quality management starts with identification of the decision environment. The decisions themselves are the key to identifying the actors (the stakeholders) in that particular decision. However, there is another aspect of the decision environment that is characterized by the institutions that not only constrain the decision but also those which are constrained by the decision.

Each of the circles in Figure 2 represents a decision arena, the institutional environment within which a decision is made. The concentric nature of the decision arenas is due to the limitations imposed by a regulative hierarchy. Decisions made at the national level (national policy) must be consistent with the

decisions made at the EU level (policy). Management decisions made at the catchment level must be consistent with national policy and decisions at the farm level (field level for land use decisions) consistent with regulations and standards determined at the catchment level which in turn are consistent with national policy, which is consistent with EU policy.<sup>7</sup>

How does this relate to development of policy and DSS? Decisions are choices made over a set of alternatives. Policy in the preceding (higher) circle determines the domain of alternatives in the lower circle. The starting point when analyzing a decision that affects water quality is to determine which of these arenas is of primary interest. Farm level decisions cannot be analyzed without assumptions about the limitations imposed by the higher levels. It is easiest to illustrate this principle with an example, the size of a tax on the nitrogen content in fertilizer.

**Figure 2.** Decision arenas for water quality management

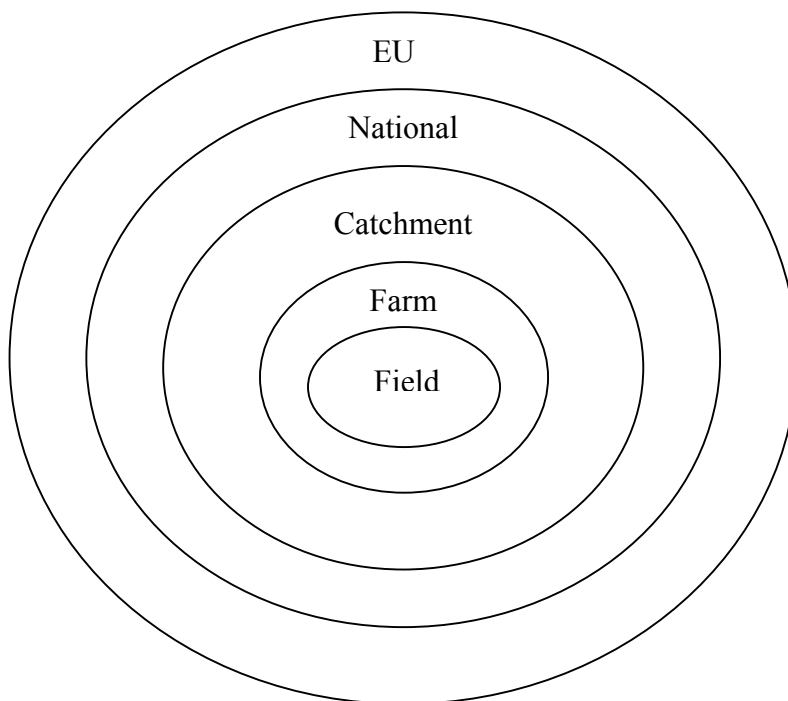

A national tax on nitrogen content changes the shape of the second circle in Figure 2, the 'national' arena. This circle defines behavior constraints imposed on all actors (activities) within the institution defined as a nation. Under a new tax policy all activities that take place within the jurisdiction of this institution must be

---

<sup>7</sup> Farms are used here as a proxy for water users at the catchment level. This group includes all users at this level: households, industrial users, etc.

consistent with the new tax. The decision alternatives facing actors are altered by the constraint imposed and the new set of alternatives must conform to the new information. Thus even though the tax in the end is expected to alter the set of decision alternatives faced by farmers, the lowest scale of decision arenas, it also changes the sets of decision alternatives for other institutions below the national arena. A catchment authority working with water quality management must take into account the effect of the tax on its decision arena. For example, the environmental benefits of investment in wetland restoration may be impacted by a nitrogen tax.<sup>8</sup> At a higher hierarchical level the proposed tax must be studied to see if it is consistent with the immediately higher decision arena, in this case EU policy.

The three models for water quality management developed in this thesis may all be described in terms of decision arenas. The first model, the DSS LENNART, was developed to be used by farmers and farm advisers for support in making field management decisions. This arena corresponds to the inner circle in Figure 2, the field level. Although the decision maker is the same as at the farm level, the farmer, the type of decision being made is more limited and a subset of farm level decisions. The types of decision alternatives that the model LENNART is designed to work with all conform to higher institutional decision arenas. What this means is that the model works within the constraints of these existing institutions and that information from these higher arenas enter the model exogenously. The model is not designed to analyze which field management practices are most cost effective for catchment management of water quality but rather which set of management practices is most cost effective for management of a particular field.<sup>9</sup>

The second model, the composite market model, is a policy for water quality management in the catchment arena (the third inner circle in Figure 2). This means that it is consistent with higher arenas, i.e. that implementation doesn't require any changes in institutions at higher levels and that information from higher levels can be exogenously included in the model. The policy does change the set of decision alternatives both at the catchment level and at lower levels. On the farm the policy may define a new set of decision alternatives that a farmer faces in making a field management decision. For example, one of the markets in the composite model constrains particular management choices; the new set of alternatives for the choice constrained farmer now includes the purchase of transferable discharge permits (TDP).

The third model, CATCH, is a decision support system for the development of water quality management policy at the catchment level. The model therefore is

---

<sup>8</sup> If a tax decreases the quantity of nitrogen leached from arable land, the reduced flow of nitrogen to the wetland will decrease the effectiveness of nitrogen removal provided by the wetland and as a result increase the unit cost of nitrogen removal. Under these circumstances, the value of benefits from investment in wetland construction as nutrient sinks will be impacted by a tax.

<sup>9</sup> However, user information stored in the model database may be used for development of catchment management policies and/or tools.

consistent with institutions at higher levels but may define new sets of decision alternatives within the catchment and at lower levels (farms). If the development of policy alternatives at the catchment level identified through use of the model is constrained by higher arenas, then this may be interpreted as an indication that lobbying efforts and/or policy reform are necessary for effective catchment management.

The use of the decision arena concept for analysis is primarily for purposes of identifying whether the proposed program creates new institutional forms, works within existing institutional forms or requires new institutional forms before it can be made operable. As described above all three models developed in the thesis work in the catchment or farm arenas and work within the existing institutional structure of higher arenas. Therefore implementation of the models doesn't require any institutional change above the catchment level.

## **2. Tools and policies for water quality management**

The following sections describe how the three models developed in the thesis contribute to the management of water resources in the catchment. The models are intended to serve as management support alternatives to be used where appropriate and in combination with other types of management support models. They are not designed to be used as an integrated universal tool applicable in all cases. The hope is that the descriptions of the problems that these models were developed to work with and how they work will allow potential users access to them as management support. Using 'the right tool for the right job' means that there must be more than a hammer in the toolbox before the user starts seeing more than just 'nails'.

Two of the models are designed to work with management support for best management practices (BMPs) as a part of agri-environmental policy. The first section below describes how these types of policies are intended to mitigate a particular environmental problem associated with water quality, that of eutrophication. This section includes a discussion of problems with implementation of BMPs and information costs. This is followed by a description of the first model, LENNART, a net-based interactive DSS. The following section describes a composite market model for Transferable Discharge Permits (TDP) that specifically includes NPS agricultural runoff. The last model of the three models described here, CATCH, is designed to support stakeholder participation in catchment management policy.

### **2.1 Agri-environmental programs**

Eutrophication is a problem that involves non-point source (NPS) pollution as a primary contributing factor. Sectorally defined discharge sources which are sufficiently concentrated may, however, be identified and abatement measures

suggested which decrease discharges from that particular sectoral source. This is the case for example, for the contribution of agriculture to surplus levels of nitrogen in catchment basins. Nitrogen is transferred from the agricultural sector by agricultural end products and by release to either air or water.

Agri-environmental policies built upon the use of economic incentives are commonly used to achieve environmental goals. In general, economic incentives are intended to induce voluntary compliance with policy objectives through profit maximizing/cost minimizing behavior. In particular, many agri-environmental programs with the goal of introducing best management practices on the farm are promoted through the possibility for increases in income from subsidies or the avoidance of decreases in income from penalties (taxes or fees). The decision to adopt or not adopt by targeted actors rests on the individual actor's estimate of the expected effect of implementation on returns. This estimate is in turn the determining factor for the success of the policy.

Many of the agronomic practices that contribute to nitrogen leaching are connected with field cultivation practices. Changes in agronomic practices, best management practices (BMPs), have been identified which could substantially reduce the level of nitrogen leaching (Leathers, 1991; Trachtenberg and Ogg, 1994; Gustafson et al. 1998). Implementation of BMPs by farmers is generally assumed to be voluntary, encouraged by support from extension services or other government programs (Reichelderfer, 1990; Leathers, 1991; Feather & Amacher, 1994; Norton et al, 1994;). However, these programs have not achieved expected results (Setia & Magleby, 1987; Wolf, 1995; Gustafson et al, 1998; Shortle et al, 2001; Collentine, 2002a).

An evaluation of the Wisconsin Nonpoint Source Water Pollution Abatement program concluded "it is reasonably clear that the low level of participation in the voluntary NPS program make up the weak link in the administrative chain between program implementation and better water quality" (Wolf, 1995, p.1021). A Swedish regional study (Gustafson et al, 1998, p.187) concludes that with regard to the lack of participation in voluntary measures "there seems to be an urgent need for an intensive programme for information, education and advisory services to farmers if the goals on water quality set by the government for the Laholm Bay area [coastal area in southern Sweden] should be achieved within a reasonable time period. But also implementation of new more effective tools seems to be necessary."

Cultivation practices that can reduce nitrogen leaching have been supported in Sweden through a program of subsidies directed at specific regions. Several measures have been promoted in this way; creation of wetland areas, extensive pasture and buffer zones along watercourses, the use of catch crops, and long term pasture. The original goal of the catch crop program when it was initiated in 1995 was that 39,000 hectares would eventually be signed up with the program. The level of compensation was set at 500 SEK/ha. During 1996, a little over 4,800 acres, representing around 12% of the goal, were included in the program. Due to this low interest the compensation level was almost doubled in 1998 to 900 SEK/ha after a recommendation by the Swedish Board of Agriculture. This increase led to a somewhat higher participation rate, an enrolment of 7,900

hectares or about 20% of the target level but the low level of participation led to a new set of recommendations from the Board of Agriculture. Participation rules were relaxed with respect to dates for sowing and plowing in the catch crop and complementary payments could be received for delayed cultivation (SOU, 1999). While the new rules have led to oversubscription in the program the question of which factors led first to the lower than expected participation rate and then to the greater than expected participation rate have yet to be understood.<sup>10</sup>

The success of agri-environmental policy, and thus the cost effectiveness of these policies, will be enhanced through an understanding of the factors that determine how producers make choices with regard to BMP implementation (i.e. when to adopt and which measures to adopt).<sup>11</sup> If these factors are better understood, then information flows may be developed which support the decision of farmers to adopt specific measures as well as support authorities in the design, implementation and evaluation of agri-environmental policy. Henry Buller observed (1999, p.105-6) in a report on the implementation and effectiveness of agri-environmental schemes, that because “Agri-environmental policy occupies an ill-defined middle ground between regulatory approaches to environmental management ...and more classic generalized market instruments ... [that] agri-environmental policy critically needs to be placed at the level of the farmer and the farm”. That is, successful programs begin with an understanding how farmers on their farms make management choices.

**Figure 3.** Adoption of BMPs by agricultural producers.

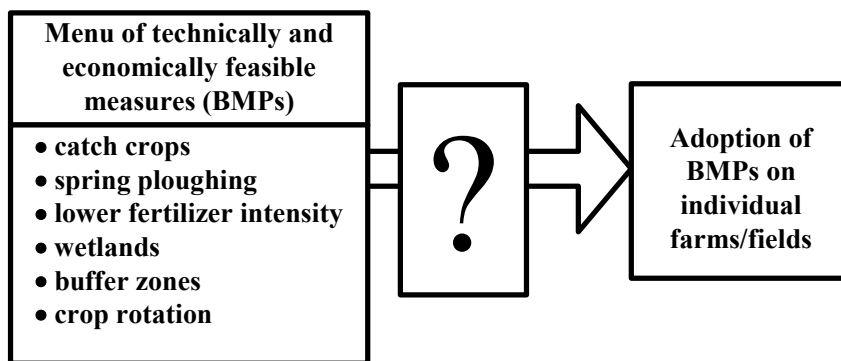

#### *Evaluation of BMPs*

One of the problems with discussion of economic analysis of agronomic measures is that there is sometimes confusion over how we are working with these measures, particularly when we are using terms such as “cost effectiveness” and

<sup>10</sup> For a more complete description of the former program and an analysis of the low participation rate see Collentine 2002a.

<sup>11</sup> See Drake, Bergström & Svedsätter (1999) or Buller (1999) for studies of how farmers’ attitudes may affect uptake in voluntary agri-environmental programs.

“economic efficiency”.<sup>12</sup> The menu of BMPs in Figure 3 lists examples of measures that are generally regarded to be of interest to reduce nitrogen leaching from cultivated land. They may or may not be cost effective or economically efficient. The uncertainty lies in where the practices are adopted, both with respect to the effect of the measure(s) on leaching and with respect to the economic effect of the measure. To move from the list of BMPs to actual adoption requires some type of policy, such as the spread of relevant information, the establishment of institutional forms, use of economic incentives, etc. These techniques that may lead to adoption of measures also have associated costs, which vary depending on factors such as the rate of adoption, monitoring, administration, etc. Cost effectiveness and cost efficiency are neither independent of the policies for implementation of measures nor independent of the adoption decisions on individual farms/fields.

**Figure 4.** BMPs, from development to adoption.

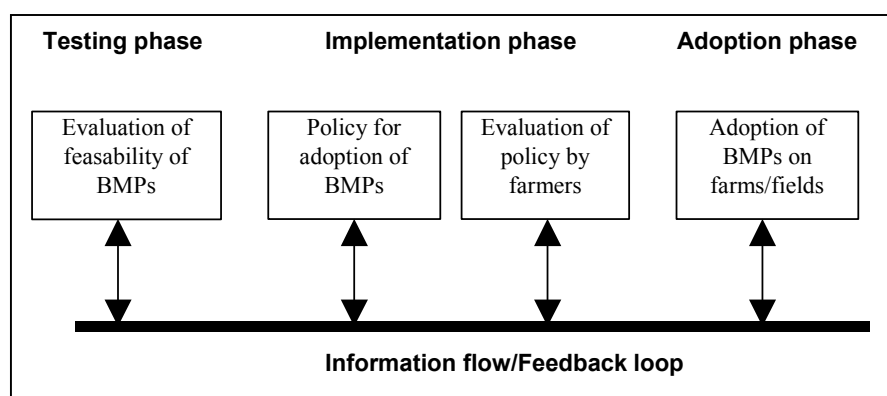

A second problem with the analysis of agronomic measures (BMPs) is illustrated in Figure 4. The path from development of adoption of BMPs moves through three phases: testing, implementation and adoption. The movement through the three phases is not necessarily linear but a feedback loop, where each of the four boxes in Figure 4 may provide feedback to a previous phase (box). The purpose of the testing phase is to look for individual BMPs that may then be included in the menu list in Figure 3. These individual BMPs must be technically and economically feasible, therefore it is necessary to perform some sort of economic analysis in this phase, but this analysis can't determine which of the measures is most cost effective, only that it is a reasonable measure to continue analyzing. In the following phase, measures that are deemed to be of interest in the testing phase are the subjects of analysis for the purpose of determining what form of policy may be most effective (reasonable) from the authorities' point of view. In the second part of the implementation phase farmers need to evaluate the policy suggestions that in turn lead into the last phase adoption. It is first when the last

<sup>12</sup> See Leathers (1991) for an in depth comparison of best management practices and socially optimal practices.



stage is complete that we can make determinations about cost efficiency as by then the total costs are included and the spatial distribution is known.

The feedback loop describes the possibility that information in that phase may lead to adaptation at an earlier phase of the measure itself, in the policy for implementation or in the decision by the farmer. For example, if a measure is not adopted then perhaps there needs to be a change in the policy for adoption (this was the case for catch crops). What this means for economic analysis of BMPs, is that the type of analysis that should be performed depends on which phase the measure under consideration is in.

Cost effectiveness, measured as the cost of nutrient reduction measured in kilograms per acre, depends then on where the measure is adopted and the cost of adoption, including the cost to the farmer and the cost for the policy. Thus, even though a particular measure may be quite costly, if there is a large effect on leaching because of where it is adopted, it may be more cost effective than a measure that carries a low cost but which because of the spatial distribution, has a low effect.

#### *Information costs, spatial scale and decision heuristics*

Information costs are directly related to the effort needed to access and process information. For example, ascertaining the weather today at the place one is standing is possible at a relatively low access cost (looking outside, opening the window, or perhaps going outside). In this case there is little effort that needs to be made to gather information. The cost of processing this information is also low if we use a simple decision rule, a decision heuristic, that weather tomorrow is most often like the weather today. On the other hand, if we were instead interested in knowing how the weather is today with respect to what is normal for this time of year or the exact level of humidity in the air, the access and processing costs would rise considerably. The access cost depends in part on what demands we place on the type of information we are interested in. The processing cost relates to how readily the information accessed may be used in supporting a decision. These two components of information costs, access and processing, are difficult to separate in practice because the decision of what type of information to look for (accessed) is dependent on how the information will be used (processed). Therefore in the following, explicit reference is made to access costs but this implicitly assumes predetermined processing costs.

Spatial information can be either site specific or general. From the weather example, we might differentiate between weather on a broad spatial scale (the weather today in Sweden) and a narrow, site specific, spatial scale (weather on the island of Lidingö, a suburb of Stockholm). The access cost of information on a broad spatial scale may be high or low, again it depends on the demands we place on the information. If the scale of weather we are interested in is broad, we can look out the window or purchase a newspaper, and check the weather; both of these associated with a low access cost, and then call this weather in Sweden. If on the other hand, we are interested in a narrower scale, predicting the weather on our particular farm, we might want to first study the correlation between local weather and weather in Sweden in general, a high access cost, and then adjust our

observation of local weather by using this correlation to predict the weather expected on the farm.

The relationship between spatial scale and access cost is represented in Figure 5. In the figure, quadrant I represents cases where there is a high access cost for information on a narrow spatial scale. This access cost falls with movement along the x axis towards quadrant II. Moving upward along the y axis would indicate an increasingly narrow spatial scale. For example, access to information with regard to fertilization schedules for a farmer could be on a broad spatial scale if the information were applicable on a regional basis based on regional climatic factors.

**Figure 5.** Access cost to spatial information.

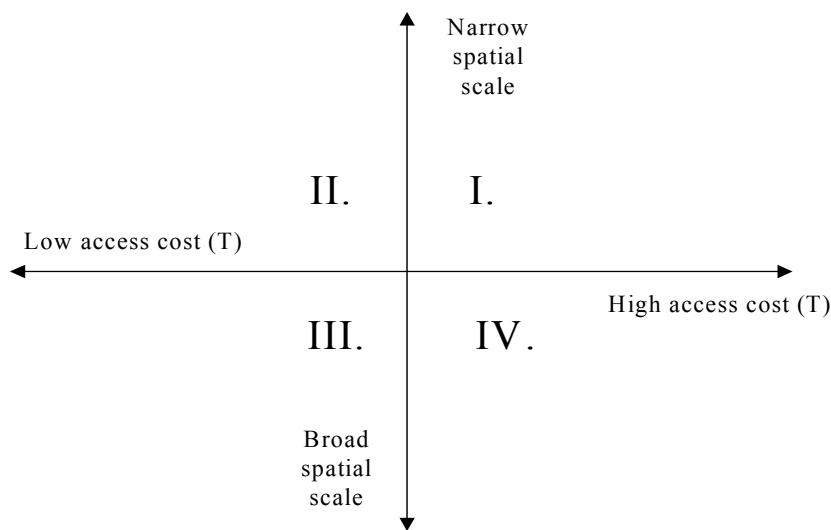

If the information were available through a phone call to a farm adviser then this could be obtained at a low access cost as well (quadrant III). However, a farmer growing a particular crop on a particular field might be interested in applying a site-specific fertilizing schedule. This may be obtained by first performing soil tests on the field and then studying and comparing research results for the particular crop and soil type using alternative fertilization schedules, all of these activities indicate an upward movement on the spatial scale. In addition, this method would also, in all likelihood, be associated with high access costs (quadrant I).

There is a trade-off that is possible to make between the scale, which may also be regarded as a proxy for reliability, and access cost. However, in certain circumstances it may be possible to gain access to locally specific information at a low cost. With respect to the fertilization example described above, another method for accessing information would be to assign a high degree of reliability to

another farmer in the same area with what might be known to be a similar type of soil and then follow the application schedule observed on this field or the schedule recommended by that particular farmer, a method which could result in a low access cost and a high degree of site specificity (quadrant II). This method is a decision heuristic, a cognitive method for reducing the decision fields of complex problems to make them tractable, a technique associated with bounded rationality.

## **2.2 Decision support for field management**

Decision support systems (DSS) are computer-based models designed to serve decision makers by processing flows of information. The starting point in the development of a DSS is the identification of the problem faced by the intended users of the system. The problem initially defined for analysis for the model LENNART was the lack of enrolment in a voluntary agro-environmental program targeted at the reduction of nitrogen leaching from cultivated land. In particular the Swedish program which offered subsidies for the cultivation of catch crops (Collentine, 2002a). Based on their analysis of the problem the development team (an economist, a soil scientist and a systems analyst) identified two elements which should be incorporated in a DSS; the possibility for the user to calculate the effect on farm income of program supported agronomic practices (BMPs) and providing the user with information on the estimated reduction in nutrient losses from adopting the practices. The first of these was perceived to be the determining factor behind the program adoption decision by farmers that resulted in the lack of enrolment in the program while the second was regarded as the social motivation for paying the subsidy to support the programs.

LENNART is a net-based decision support system (DSS) that has been designed to evaluate agronomic practices to reduce nitrogen leaching. The model is designed to be used by individual farmers or farm advisers to explore results of modifications of farming practices, both the effect on the income of the farmer(s) and the effect on the leaching of nitrogen. Some examples of these BMPs are catch crops, cultivation timing and fertilizer application timing. The base unit of this model is the field level (hectare). Farms, sub-catchments, catchments or other regions of interest can be built up from a field level. The principle idea is that each user can adjust the model to reflect local conditions based on user information. This allows for flexibility in use of the model and ensures that the user is in control of the results generated by the model through control over model inputs.

Costs evaluated at the field level for each agronomic activity or effect associated with the cultivation of catch crops are the determining factors for the decision by individual farmers to enroll acreage in the catch crop program. Modeling this farm level decision may be done by first disaggregating the activities and then estimating each of the choice variables. This is the linear cost model described in Article 1. For catch crops, Collentine (2002a) identifies four agronomic activities and effects with a total of 14 choice variables at the farm and field levels. If the costs represented by the choice variables were known, then performing the calculation is a relatively simple procedure that could be done on a handheld calculator without a great deal of effort. However, since the choice to implement the use of catch crops on the farm is based on the assumption that the technique is

not already being used, it is reasonable to assume that there is uncertainty with respect to the expected values. A farmer evaluating the decision may be expected to perform some type of ‘what if’ (sensitivity) analysis. What if the expected cost variables were lower/higher than average, how might this affect the cost of the agronomic activity and in turn, the decision to adopt the measure?

If a farmer were to choose only three values for each of these uncertain values (low, average, high) to use in calculating expected costs, the total number of cost combinations to evaluate in one time period, are equal to  $3^{14}$ , for a total of 4,782,969 possible cost combinations! Furthermore, before solving the total costs for each combination of costs during one time period is even possible, high and low estimates for each of the variables must be made.<sup>13</sup> In addition, the costs of accessing the information needed to make these estimates also need to be included in the choice model.

### *Bounded rationality and the use of heuristics*

In the 1950s Herbert Simon (1956) introduced the concept of bounded rationality to describe the process by which decision makers are limited by cognitive constraints in the search for, and evaluation of, the information used in making decisions. In the neo-classical model of economic optimization, a rationally economic actor would be expected to evaluate all the consequences of the decision under consideration and to choose the alternative that maximized returns (utility). However, what Simon introduced was the idea that each actor is limited by both knowledge and computational capacity and must of necessity limit the alternatives and consequences considered to make the decision tractable. This then results in a bounded rational choice rather than an optimal choice being made, a choice that is described as ‘satisficing’ rather than ‘optimizing’ from the decision maker’s perspective (Simon, 1987; Hogarth, 1987). Optimization theory disregards decision processes and cognitive limitations (van den Bergh et al, 2000; Laville, 2000). Application of the theory of bounded rationality explicitly concentrates on the role of the decision maker with respect to the problem at hand, the processes that are used for decision making as well as the limitations imposed by the computational capacity of individuals.<sup>14</sup>

In the choice model described above, it was noted that a rational farmer could perform as many as 4,782,969 calculations in order to estimate the economic consequences of cultivating a catch crop on a particular field before determining the optimal choice. Even if an impulse to perform this heroic task were exhibited, the computational demands placed on the decision maker would be next to impossible to satisfy without some type of decision support model. In addition, even if it were feasible to somehow perform all of these operations, the associated

---

<sup>13</sup> Assuming a triangular distribution for each variable makes the calculation of the average a simple combination of these two estimates.

<sup>14</sup> See van den Bergh et al (2000) for a discussion of the implications for environmental policy of models which assume that satisficing models based on bounded rationality rather than optimization models better explain observed individual behavior.

opportunity cost would in all likelihood dominate all possible gains. Leading the rational farmer to conclude that the measure should either not be adopted or that some other lower cost method, with a lower expected information cost for making the decision, should be found. Heuristics are used as a method by rational actors for reducing information costs in decision-making.

The model builds on the principles of decision making under uncertainty. Specifically, it is designed to take into account user decision heuristics such as anchoring, availability and representativeness (for an overview of these concepts see Tversky and Kahneman, 1982). Persons faced with complex decisions where there is uncertainty involved with respect to the outcome of the decision intuitively use these decision heuristics. These heuristics serve as a method of structuring subjective probabilities associated with possible outcomes. Anchoring is often used as a technique for numerical prediction when there is a value available. The default values provided by LENNART are designed to serve as available values where anchoring is a factor. Availability refers to access to information for making estimates of the frequency of events. LENNART provides access to other users frequency estimates as well as expert estimates through the use of links to other sources of information. For example, Figure 6 illustrates how user inputted costs for sowing catch crops compare to the estimates made by the Swedish Board of Agriculture. Representativeness is used in making judgments about the stationarity of observations, that is, whether the events associated by the user for decision support belong to the same class of events. To support the use of this heuristic,

**Figure 6.** Comparative summary page in LENNART for farm users (in Swedish).

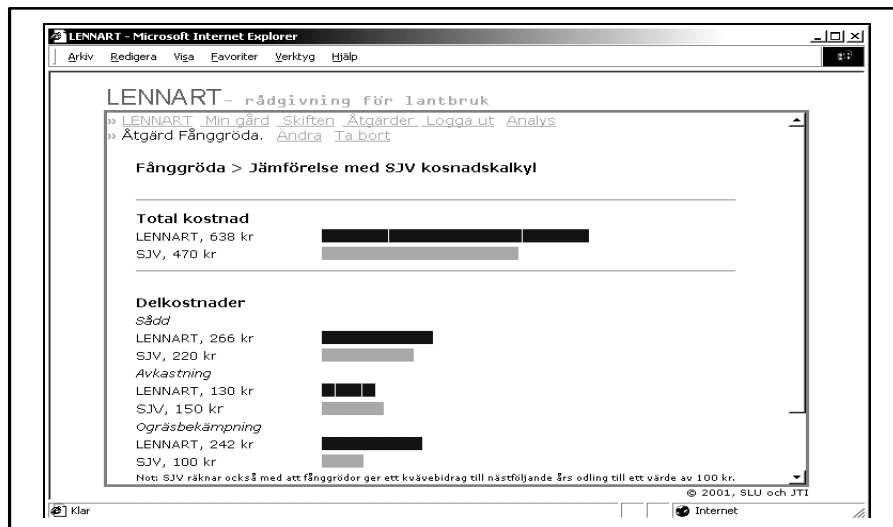

LENNART provides access to other classes of users in the database and supports the user in determining whether the chosen classes are representative for the decision being considered. By taking into account these LENNART provides a unique opportunity through the use of modern information techniques to explore

how these types of decision heuristics can be actively incorporated into a decision support tool.

### *Net-based platform for a DSS*

LENNART has been programmed to be used from a server based web site accessed through the Internet. There are three primary factors that led to this choice of platforms; access factors, development factors and database factors. A server-based program promotes access for a wide group of intended users. Multiple users from individual computers can access the site. The only personal computer software requirement being a standard web navigating program (Netscape or Explorer). Enabling access to the program through individual computer connections also allows the program to be demonstrated in a variety of environments; farm advisers can demonstrate use of the program in consultations with farmers during farm visits, the program can be demonstrated and used by groups in seminars, in addition to being used pedagogically, the web site address can also be linked to other sites or promoted through campaigns in other media as well as passed on from user to user.

Development of the model can be continuous over time as control over the version being used is determined through the server. This quality also means that no problems arise with versions being used that are out of date. Each time a user logs on the version that becomes available is determined through commands on the server. This also allows for partitioning over time to test development of model components. Experimental versions can be tested and results compared so that user reference groups are designated by the version that they are using rather than determined in advance. For example, inclusion of a wizard format or tutorial can be tested by incorporating that component into the model made available to users on the server over for a specific period of time or a specified number of runs. Results from this partitioned model can be compared and choices made by model developers with respect to incorporation or development of the most favorable components. The net-based format also allows for incorporation of changes in development of the natural science process based sub-model SOILN DB (Johnsson et al, 2002). The server platform of LENNART allows changes to be made in the user available model as soon as new information becomes available. The entire model doesn't need to be replaced, just those changes which are made to the model. This makes it possible at low cost, for the model LENNART to incorporate the best information available.

The location of the model on a server also means that the database which is developed as the model is used is also located in one place and can be accessed from anywhere by designated users. As new data becomes available, i.e. every time the model is used, this data is directly available on the server. As described in more detail below in the section on decision scenarios, this database function is important in different ways for different categories of users. The immediacy of availability supports both users that are interested in comparative data and users that are interested in aggregate data for policy evaluation and design. The partitioning described above is also possible with respect to the database. Open

access to the entire database through the Internet makes it possible for those users that are interested in the model to actively work with the database for this purpose.

The model currently allows users to evaluate the economic effect and the expected reduction in nitrogen leaching from cultivation of catch crops for a set of crop rotations in a specific area of Southern Sweden. Expansion is planned to both cover a larger geographic area and to include a greater number of soil types and crop rotations. In addition, the development team plans to improve the graphic interface through the use of focus group tests. Preliminary work is also underway to allow the evaluation of other field management measures in LENNART. New measures planned for development in extensions of the model include the reduction of fertilization intensity on fields and measures where timeliness is a factor such as the timing of cultivation in combination with other practices and the timing of fertilizer applications. Since measures where timeliness is a factor may have an effect on other farm activities beyond the individual field, a preliminary study of these types of measures is necessary before they may be included in LENNART.

### **2.3 A market for tradable discharge permits**

Environmental policies that establish a tradable discharge permits (TDPs) system are economic instruments that offer a great deal of flexibility to polluters and thus are often construed to be cost effective.<sup>15</sup> This has led to a great deal of enthusiasm for TDP policies and led to rapid development and design of programs of this type (Woodward et al, 2002; EPA, 2003). Unfortunately, as Stavins (1995, p.9) observed “In some cases, environmental policymaking has outrun our basic understanding of the new pollution control instruments” and “Consequently, the claims made for the cost effectiveness of marketable permit systems often have exceeded what can be reasonably anticipated.”

Achievement of mandated water quality standards has increasingly focused on the role of NPS discharges, in particular, runoff of nutrients from agricultural activities (EPA, 2000; Horan et al, 2002). The use of TDP markets as a policy solution has been advocated both by economists and policymakers as the most promising policy alternative, the most cost effective means, of meeting environmental targets. The United States Environmental Protection Agency in a recent report (EPA, 2003) “believes that market-based approaches such as water quality trading provide greater flexibility and have potential to achieve water quality and benefits greater than would otherwise be achieved under more traditional regulatory approaches” and that “market-based programs can achieve water quality goals at a substantial economic savings”. Although the validity of this statement may be questioned, what is certain is that the lower the total cost of

---

<sup>15</sup> See Collentine (2002b) for an analysis of why under a standard set of assumptions tradable permit systems will always appear to be the most cost effective policy alternative.

a particular policy such as trading, the greater is the possibility for achieving savings.<sup>16</sup>

In a TDP market, the price signal provides information to market agents, dischargers of pollution, which may be used for valuation of their decision alternatives, in particular, their decisions with respect to implementation of abatement measures. The price signal provides information about the minimum value assigned to the discharge permit by purchasers and in addition, is also an indication of their marginal abatement costs. The underlying assumptions that abatement costs per unit of emission vary among discharge sources, that information about abatement alternatives is available to the source but not to other actors and that price signals convey this information, lead to the conclusion that a TDP market offers a cost effective policy alternative for achieving discharge targets. A trading program through “introducing transferability ... offers the potential for substantially lowering costs and for encouraging technological [abatement] progress” (Tietenberg, 2000, p.176).

Tradable discharge permit programs may be economically efficient if transaction costs are internalized and individual abatement cost functions are known to permit holders (owners). This latter condition is the information needed to motivate trading. Least cost solutions are possible even when this information is not publicly known. However, discharge loads need to be quantifiable before permits can be allocated, that is, before property rights to these loads can be assigned to individual dischargers. The permits must have a common unit of measure to define value for the buyer and seller. A paper by (Malik *et al.*, 1994, p.477) identifies the problem of measurement in trading programs explicitly, “Since nonpoint loadings cannot be measured, they cannot be traded directly.” Permits and hence tradable permit systems have no value unless they refer to a specific quantifiable loading. This quantity provides the measure that makes allocation of property rights possible based on ambient water quality defined as a limit on loading.

#### *Composite market model for TDP*

The advantages of a composite market model are the flexibility that the model offers a catchment based agency for implementation of a TDP system. The model makes possible the development of TDP markets adapted to the particular needs and limitations of individual catchments. Implementation may take place over time without major new investments and adapt to new information and technological innovations as these become available. Cost efficiencies arise in the composite market model in part through dividing a TDP market transactions into functional components and thereby providing flexibility to the catchment agency in the development of market incentives, i.e. price signals. The composite market disaggregates permit transactions into two primary markets and one secondary

---

<sup>16</sup> The cost effectiveness of taxes, a traditional regulatory approach, is not explicitly evaluated anywhere in this thesis. Although in many circumstances a tax may offer a possibility for low transaction costs, the primary intention of the research in this thesis is to explore design options for an effective tradable permit market i.e. not the evaluation of solution alternatives.



market (Figure 7). All three of these markets provide price signals for dischargers to use in making abatement investment decisions. Compared to conventional trading programs, the composite market design enhances the opportunity for TDP programs to achieve their goals by offering a market structure which reduces the transaction costs of information, assigns limited property rights and can be implemented in stages. These factors all contribute to realizing the potential offered by viable markets in discharge permits.

**Figure 7.** Information flows in a composite market model for agricultural discharges.

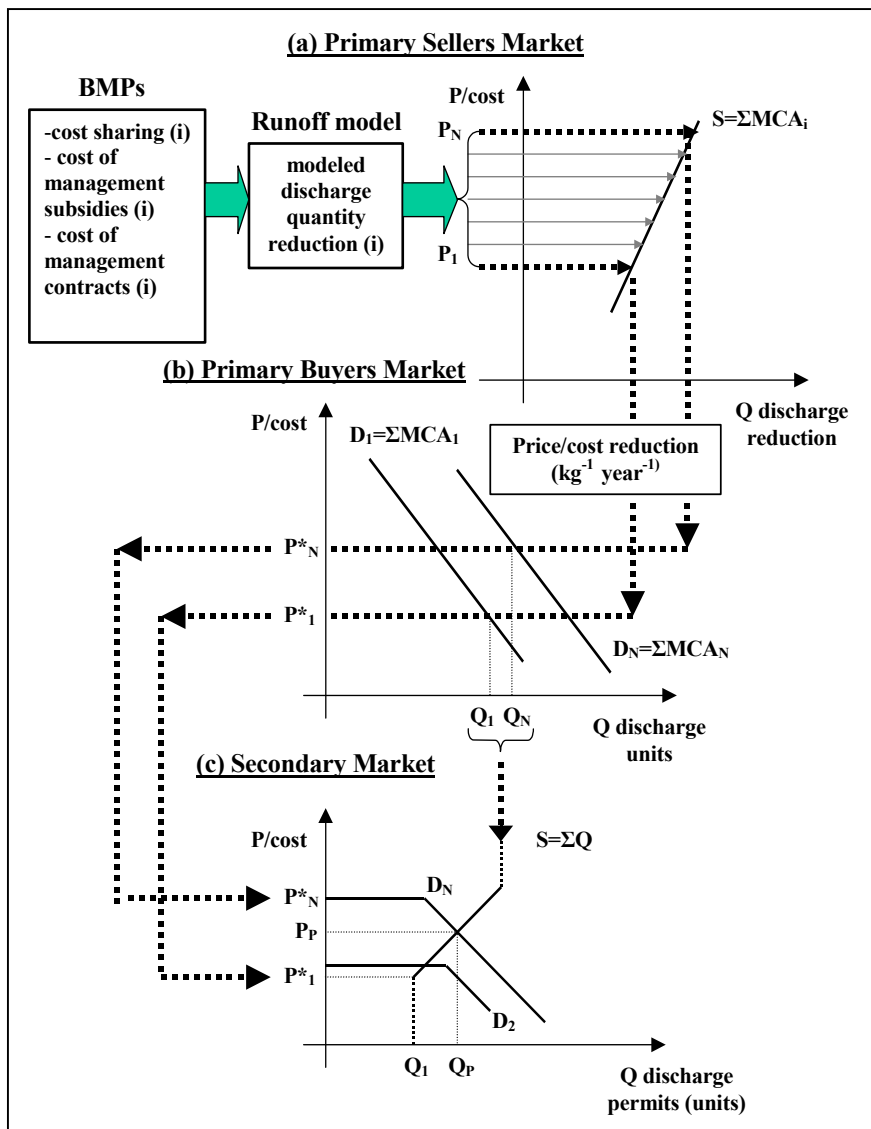

### *Property rights*

The composite market structure assigns and transforms property rights in the two primary markets. In the primary sellers market the regulatory agency, the buyer, assumes liability for controlling the terms of the transaction, that is, monitors and enforces the contractual agreement. For example, in the case of a uniform subsidy for a BMP such as spring tillage, the regulatory institution ensures that the recipient of the payment performs in accord with the agreement and is able to take actions if a violation of the terms is discovered. Therefore in this market the buyer, the agency, assigns limited property rights to the transaction by assuming the liability for control of the agreement. In the primary buyers market the regulatory agency, the seller, offers a permit, a license, for a specific quantity of discharge over a specified period of time. The limited property rights represented by the discharge permit are also transferable to another party subject to approval of the transfer by the issuer of the permit, the regulatory agency. The buyer's liability in this market is to conform to the limits specified in the permit and to have agency approval before transferring the permit. These liabilities follow the permit in all transactions in the secondary market. There are no new property rights assigned in this market beyond those designated by the original permit issue. The control of the use of the permit, monitoring and enforcement, remains with the regulatory agency. Thus the sellers market transfers liability for control of discharge reduction activities to the buyer and the buyers market assigns a limited set of property rights to the permit purchaser that are not related to the control of reduction credits

### *Transaction costs*

The composite market system is designed to minimize transaction costs in several ways. The information and search costs for market actors for a trading partner are minimized through the primary markets. In both of these markets a regulatory agency serves as one part in the transaction, the other part is a discharging source. There are two types of discharge sources; the discharge source that is constrained by regulation into making a choice with respect to investment in abatement measures and the discharge source that is not constrained but which has the option of making the choice if it is economically advantageous. The choice constrained discharger represents demand for permits in the primary buyers market. This type of discharge source is faced with a choice between investing in abatement and purchasing corresponding discharge permits. The buyers market provides a price signal for use in making this decision. The permit price represents the relevant marginal cost of abatement for other discharge sources. The information costs for each source are limited to those for evaluating their own abatement cost for a particular level of reduction. If there is a repurchase clause in the permit then this information can be evaluated as it becomes available without incurring additional costs for the timeliness of the decision.<sup>17</sup>

---

<sup>17</sup> An example of this is the observation by Netusil and Braden (1993) that "waiting to contract [for abatement] may greatly reduce/enhance a landowners gains from contracting".

The non-constrained discharger will choose to offer reduction credits for sale in the primary sellers market if the particular measure represents a gain in income. The price paid by the regulatory agency is transformed through a model into a marginal abatement cost for a specific reduction quantity. The information costs for discharge sources in this market are restricted to the costs for the contemplated abatement measure (see Collentine, 2002a). The price in this market is an indication of the marginal abatement cost that the agency currently pays for reduction costs and serves as a price signal for sources in their investment decision.

Another way that the composite market minimizes transaction costs is where there are decreasing marginal transaction costs in the market. Several studies (Stavins, 1995; Tietenberg, 2000) have suggested that transaction costs fall as the number of transactions increases. This effect is due to several factors; the presence of fixed transaction costs, the increased ability to process information made available through repetition and the decrease in negotiation costs possible through repeated transactions. As noted above, information costs for sources are restricted to either the costs of implementing a specific measure or the costs of estimating abatement costs. Once these costs are incurred they represent a sunk cost for decision purposes and ex post are no longer relevant as transaction costs for additional decisions (Buchanan, 1969). For sources repeating the evaluation of a particular abatement measure in a new environment (a new field for example) many of these adoption costs are the same and the incremental changes easier to calculate (Collentine, 2002a). Finally, since all transactions in the two primary markets represent negotiation with the same agency, standardization of the contracts is possible which leads to falling transaction costs as the number of agreements increases.

## **2.4 Stakeholder participation in catchment management**

Management of water resources in catchment areas is a question of allocating resources based on priorities in the particular catchment. Water allocation supports a complex set of socioeconomic and ecological systems, which may be negatively affected under alternative management strategies. A concurrent emphasis on involving stakeholders in resource management has created a need for the development of decision support techniques to assist stakeholders in this process. The CATCH model attempts to provide a structural method for involving stakeholders in the allocation of water resources in catchment areas.

The CATCH model operationalizes principles of deliberative democracy into a framework that promotes discourse and deliberation while maintaining a focus on organizational tasks.<sup>18</sup> The building blocks of the model are descriptions of

---

<sup>18</sup> See Dryzek (2000), Pellezzoni (1999) or Jacobs (1997) for descriptions of theory and principles which support the idea of deliberative democracy.

stakeholder relevant socio-economic parameters for the particular catchment.<sup>19</sup> There is no quantitative measurement of the parameters; instead the relationships between parameters are qualitatively described as a part of the process. Tradeoffs are a part of the deliberative discourse and may occur at various stages in planning and implementation. The language for evaluation of the tradeoffs is the set of common definitions developed for the model.

Identification of the parameters is a deliberative discursive task. These parameters should describe the relevant goals for evaluating management alternatives in the catchment area.<sup>20</sup> These are the values, which drive the allocation between competing interests, i.e. the provision of water services. Since the parameters evolve through discourse between individual stakeholders, they represent not only individual tastes and preferences but also, the preferences of the interest groups, which these individuals implicitly represent. In this sense the expressed values, described here as socio-economic parameters, represent a domain of both private and public interests. The list of parameters in Figure 8 evolved from a dialogue in an experimental setting (Collentine et al., 2000).

**Figure 8.** CATCH: Example of socio-economic parameters

- **Local support:** level of support for proposals and decisions amongst local present and future stakeholders. The greater the local support the less risk for conflicts between stakeholders.
- **Bio-diversity:** landscape and biotope variation, both with respect to the presence of species as well as environment.
- **Recreation:** free activities which presume access to natural resources, such as hiking, bird watching, swimming etc.
- **Diversified economy:** a variety of business activities. Greater variety provides greater regional economic stability.
- **Culture:** present and historic expressions of human culture.
- **Hydrological balance:** water levels are maintained at a natural level. Balance between rate of withdraws and recharging to avoid undesired changes in water tables.
- **Regional economy:** diversified and effective exploitation of resources in addition to economic growth.

Once a set of socio-economic parameters has been agreed upon, the next step is to evaluate the relationships between the parameters. What effect does a change in one parameter have on the remaining parameters? This is analyzed by constructing a series of matrices with each parameter listed on each axis. The relationships are decomposed into two spatial components, regional and local effects, in addition to positive and negative changes in individual parameters to describe the range of the

---

<sup>19</sup> Since these parameters may include bio-physical indicators such as ‘bio-diversity’ and ‘hydrological balance’ (see Figure 8) references in the text to socio-economic parameters should be broadly interpreted to include indicators as well.

<sup>20</sup> These parameters correspond to the ‘fundamental objectives’ used in multi-attribute utility techniques. See for example Gregory (2000).

relationships. For example, Table 2 describes the cross effects of positive changes in the socio-economic parameters on a regional level. There are four possible types of effects in the relationship between two variables. In Table 2 a positive effect (+) indicates that a positive change in the row variable leads to an increase in the column variable. Both the type of change and the resultant increase are defined by the consensual definitions of the socio-economic parameters (Figure 8).

This discussion, deliberation and evaluation of effects as represented by the matrices described here, is the core of the model. It is during these deliberations that a common language evolves which may be used to analyze allocation problems and argue for particular allocations. It is also possible to incorporate external expertise and informational sources into the deliberation process. For example, it may be necessary to describe the present state of biodiversity at the site or in the catchment, in order to analyze whether a change may lead to an expected increase or a decrease in biodiversity. It is easier to translate this need for more information into a search for unbiased information, as at this point in the process, strategic positioning, based on stakeholder interests in allocations, has not yet entered the decision arena.

The model is unique in several ways. It has specifically been designed to support stakeholder involvement in water management at a catchment level. It provides a systematic method for developing management objectives, as well as a method for

**Table 2.** CATCH: Cross effects of positive changes in socio-economic variables on a regional level. (+ = positive effect; - = negative effect; 0 = insignificant effect; +/- = indeterminate effect)

<i>REGIONAL</i>	Cult.	Bio-diver.	Div. econ.	Hydro. balance	Local support	Reg. econ.	Rec
Culture		0	0	0	+	+	+
Bio-diver.	0		0	0	+	0	+
Div. econ.	0	+		+/-	+	+	+
Hydro. bal.	0	+	+		0	+	0
Local supp.	+	+	+	+		+	+
Reg. econ.	0	-	+/-	0	+		0
Recreation	0	+/-	0	0	+	+	

evaluating individual proposals. In addition, the universally applicable model may serve in catchments where stakeholders are directly involved in the decision making process, involved in an advisory capacity, or perform a more limited role in planning of the type often referred to as focus groups.

### 3. Conclusions

The purpose of this thesis is the development of policies and tools for the management of water resources at the catchment level, with an emphasis on water quality issues. The results of this research effort are the three management support models described in the thesis; a DSS for field management, a policy design for a tradable permit program and a DSS for stakeholder participation in catchment management. There are several common factors in all three of the models. Firstly, the models have all been developed within the prevailing decision environment. Secondly, the analytical method used has been to start with identification of the problem and the relevant decision makers. Thirdly, each of the models focuses on the flows of information to decision makers. Fourthly, the models all include a natural science perspective either explicitly incorporated in the model or implicitly included as part of the model design. Finally, each of the models is compatible with other models and techniques for water management.

The starting point in the body of research presented in the three models has been the institutional conditions prevailing in OECD countries.<sup>21</sup> The push for management of water resources both in the EU through the Water Framework Directive (WFD) and in the US has opened up a need for management tools that have been developed for use at this level. A catchment focus presumes that there are advantages to management at this level. The primary reason for advocating management is that water allocation/reallocation decisions have the greatest impact on local interests, stakeholders. Allocation decisions between conflicting interests are both quantity and quality decisions. Water quality management is spatially local, that is, there must be spatial contact surfaces for polluting activities to have an impact on water quality. Development of catchment management tools therefore should include local stakeholder interests and spatially local quality problems as well as work within the institutional framework at the catchment level.

Two of the models were developed to work toward resolution of a specific environmental problem, eutrophication. Eutrophication is caused by an overabundance of nutrients (nitrogen and phosphorus) in bodies of water. The contribution of agricultural practices to the problem through runoff and leaching is significant. Agri-environmental policies have concentrated on the voluntary and regulated adoption of Best Management Practices (BMPs) to reduce the flows of nutrients coming from farming. Farmers and their field management decisions are the focus of the DSS LENNART. Tradable permit programs offer greater possibilities for cost efficiencies if marginal abatement costs vary widely across discharge sources. If non-point sources (NPS) such as agricultural producers can be included within a nutrient emissions trading program the potential benefits increase. Relevant decision makers in a viable trading permit program include both

---

<sup>21</sup> While this focus on institutional relations within OECD countries was used to develop the models, the principles underlying the models are universal and may be used to develop similar models within other institutional structures.

discharge source decision makers and regulatory authorities. The third model addresses the problem of how to identify stakeholders and how to include stakeholder values in management decisions.

Information flows are the support for decisions. Access to information has a cost, it must be searched for and then processed for the particular decision. These costs may be included as transaction costs when evaluating a particular decision however after they have been incurred they represent sunk costs for decision purposes. These information costs represent the cost of decision making in a 'messy' world of time constraints, partial (asymmetric) information, site-specific physical parameters and individual values.

Given the high cost of full or perfect information, Herbert Simon (1956) suggested that decision makers make their choices in a world of 'bounded rationality' where choices are not always optimal but they are satisfactory in that particular situation. One of the problems with the theory of bounded rationality was that it was difficult to determine a decision rule for analytical purposes that corresponded to the simple decision rule associated with optimality. Thus while it appeared that Simon's theory explained observed behavior in a more satisfactory way than the rational man argument of neo-classical analysis the lack of decision rules was an impediment to development of models. Two psychologists, Daniel Kahneman and Amos Tversky, analyzing decisions made in experimental settings suggested that decision makers used simple decision aids called heuristics that lowered information costs. Three general types of these 'rules of thumb' were identified by Kahneman and Tversky (Tversky and Kahneman, 1982); representativeness, anchoring and availability. Design of the model for field management decisions, LENNART, builds on and supports the use of these decision heuristics by farmers.

Prices and costs are signals of information to decision makers. A price in a competitive environment represents the marginal cost of production. The price of a trading permit in a competitive market represents the marginal abatement cost of discharge sources and therefore can be used in making abatement investment decisions. If however, the price is unreliable as an indicator of marginal abatement costs it has a low informational value. The structure of the composite market model is designed to increase the reliability of permit prices and the flow of information to discharge source decision makers.

Representation of stakeholder interests can take many forms. If it is assumed that preferences are stable and independent of each other, then evaluation of stakeholder interests can take place for example as a survey where the elicited individual values are aggregated and then used for making a decision. The simplest form of this is representative democracy. If however, preferences (values) are dynamic and develop through interaction and flows of information, then discourse and deliberation can be methods that support the development of collective preferences. The model CATCH is an operational structure for creating an environment of discourse and deliberation among stakeholders.

Each of the three models includes a natural science perspective. The DSS for field management includes a database (SOILNDB) for estimating the effect on

nitrogen leaching when field information for calculating the economic effect of BMPs is entered by the user. The reason for including leaching estimates is pedagogical; including the estimates will make these values available to the user. For other users such as researchers or authorities the leaching estimates may be used for program evaluation purposes. An integral component of the composite market model is the use of natural science models such as SOILNDB for calculating nutrient losses (runoff). The simulated quantification of losses allows these modeled values to be used as *fiat* values for assigning limited property rights to NPS discharges. Without acceptable natural science models the composite market model cannot be adopted. The core of the CATCH model is the definition by stakeholders of socio-economic parameters and the relationships between these parameters. Some of these parameters are likely to be biophysical (hydrological balance for example) or have important biophysical characteristics (bio-diversity for example) and the relationships defined will often be bio-physically dependent. The principles of discourse and deliberation described in the model include access to expert information in areas of natural science for definition of the model matrices.

The models developed from the research are not comprehensive. They are designed to be used separately or in combination with the other models described here or with other management models. Each of the models may be an appropriate choice in a given set of circumstances or for a particular problem. It may be that these models over time will evolve into other subsets of models or that design elements are used in developing new models. Including three new models for catchment management increases the flexibility of catchment management. Providing access to additional tools may allow decision makers to see more than just ‘nails’.

### *Further research*

In the body of work presented in this thesis there are both model development issues and theoretical development areas that are of interest for further research. Since all three models are theoretical proposals for applied tools or policies to work with current problems, the issue of primary interest is the implementation of these models. Results from implementation of the models will generate data sets of how users express their preferences in their choices. This data in turn may be analyzed to gain insight into these processes and the development or testing of theories that may explain these processes. The development plans described below may be seen as the immediate stages suggested as necessary for implementation of the models.

A public domain prototype of the model LENNART is presently available to users on a web server. This prototype is limited to the evaluation of catch crops on particular soils and crop rotations in a specific climate area of Southern Sweden. Development of the model includes expansion of the natural science database to include more parameters but more importantly, the program needs to expand the number of BMPs, which the model may be used to evaluate.

Implementation of the composite market model is possible to perform in stages. The first of these stages is the calculation of marginal abatement costs across NPS



dischargers in a particular catchment area. Current support for measures to reduce nutrient runoff can be used as the basis for estimating the cost per unit of reduction for sources by type. For example, current per hectare subsidies paid out to farmers for cultivation of catch crops or spring tillage may be used in combination with a nitrogen leaching database (SOILNDB) to differentiate between sources with respect to the model calculated marginal abatement costs. Development of a program for constraining discharge sources successively is the next stage for implementation of the composite market model. As source constraints are adopted the calculated marginal abatement costs calculated in the first stage may then be used to set permit prices. At this point all three markets within the composite model are active and as new information becomes available and the process repeats itself the composite market matures.

The next stage toward implementation of the model for stakeholder participation, CATCH, is to evaluate the results of using the model with different combinations of stakeholder types. An application is planned for a catchment area in Southern Sweden that will test the model with four types of stakeholders; two homogenous and two heterogeneous groups of 8-10 persons. The working hypothesis to be evaluated in the study the importance of the selection of the stakeholder group for development of the model matrices. If there is wide variation in parameter choices between the four groups then this is an indication that the stakeholder selection process must be included and developed as a part of the model. Limited differences in the results would support the present model assumption that stakeholder selection is of limited importance.

**Acknowledgements** Development of the three models described in this thesis was made possible by financial support from the Swedish Foundation for Strategic Environmental Research (MISTRA), under the auspice of the Swedish Water Management Research Program (VASTRA).

## References

- Adaman, F. and P. Devine, 2001. Participatory planning as a deliberative democratic process: a response to Hodgson's critique. *Economy and Society*, 30(2): 229-239.
- Bergstrom, J.C., K. J. Boyle and G. L. Poe, 2001. Economic Value of Water Quality: Introduction and Conceptual Background, In Bergstrom, J.C., K. J. Boyle and G. L. Poe (ed.), *The Economic Value of Water Quality*, Edward Elgar, Northampton, MA.
- Buchanan, J. M., 1969. *Cost and Choice: An Inquiry in Economic Theory*. The University of Chicago Press, Chicago, IL.
- Buller, H., 1999. Evaluating participation in agri-environmental schemes. In Schramek, J., D. Biehl, H. Buller and G. Wilson (ed.), *Implementation and Effectiveness of Agri-environmental Schemes Established under Regulation 2078/92. Project FAIR1 CT95-274, Final Consolidated Report*, Frankfurt: 105-134.

- Collentine, D., Å. Forsman, S. Kallner and A. Ståhl-Delbanco, 2000. Systematic Decision Support: Achieving ecological, social and economic sustainability in a catchment area (in Swedish). *Vatten* 56: 169-176.
- Collentine, D., 2002a. Economic Modelling of Best Management Practices (BMPs) at the farm level. In Steenvoorden, J., F. Claessen and J. Willems (Editors), *Agricultural Effects on Ground and Surface Waters*. IAHS Publication no. 273., Oxfordshire, UK: 17-22.
- \_\_\_\_\_, 2002b. Search for the Northwest Passage: the assignment of NSP (non-point source pollution) rights in nutrient trading programs. *Water Science and Technology*, 45(9): 227-234.
- Drake, L., P. Bergström and H. Svedsäter, 1999. Farmers' attitudes and uptake. In Van Huylenbroeck G. and M. Whitby (ed.), *Countryside Stewardship: Farmers, Policies and Markets*. Elsevier Science Ltd, Oxford, UK: 89-112.
- Dryzek, J., 2000. *Deliberative Democracy and Beyond: Liberals, Critics, Contestations*. Oxford: Oxford University Press.
- Feather, P.M. and G. S. Amacher, 1994. Role of information in the adoption of best management practices for water quality improvement. *Agricultural Economics*, 11: 159-170.
- Gregory, R., 2000. Valuing Environmental Policy Options: A Case Study Comparison of Multiattribute and Contingent Valuation Survey Methods. *Land Economics*, 76(2): 151-173.
- Gustafson, A., S. Fleischer and A. Joelsson, 1998. Decreased leaching and increased retention potential co-operative measures to reduce diffuse nitrogen load on a watershed level, *Water Science and Technology*, 38(10): 181-189.
- Hogarth, R., 1987. *Judgement and Choice*. John Wiley & Sons, New York.
- Horan, R.D., J. S. Shortle and D. G. Abler, 2002. Point-nonpoint nutrient trading in the Susquehanna River basin. *Water Resources Research*, 38(5): 1-13.
- Jacobs, M., 1997. Environmental Valuation, Deliberative Democracy and Public Decision-making Institutions. In Foster, J. (ed.), *Valuing Nature? Ethics, economics and the environment*. Routledge, New York.
- Johnsson, H., M. Larsson, K. Mårtensson and M. Hoffman, 2002. SOILNDB: a decision support tool for assessing nitrogen leaching losses from arable land, *Environmental Modelling & Software*, 17: 505-517.
- Kahneman, D., P. Slovic and A. Tversky, (ed.), 1982. *Judgment under uncertainty: Heuristics and biases*. Cambridge University Press, UK.
- Laville, F., 2000. Foundations of procedural rationality: Cognitive limits and decision processes. *Economics and Philosophy*, 16: 117-138.
- Leathers, H. D., 1991. Best Management Practices Versus Socially Optimal Practices. In Just, R. E. and N. Bockstael (ed.), *Commodity and Resource Policies in Agricultural Systems*, Springer-Verlag, Berlin.
- Malik, A. S., B. A. Larson and M. Ribaudo, 1994. Economic Incentives for Agricultural Nonpoint Source Pollution Control. *Water Resources Bulletin* 30: 471-480.
- Netusil, N.R. and John B. Braden, 1993. Market and bargaining approaches to nonpoint source pollution abatement problems. *Water Science and Technology*, 28(3-5): 35-45.

- Norton, N., T. Phipps and J. Fletcher, 1994. Role of voluntary programs in agricultural nonpoint pollution policy. *Contemporary Economic Policy*, 12: 113-121.
- National Research Council (NRC), 1996. *Understanding Risk: Informing Decisions in a Democratic Society*. Washington, DC: National Academy Press.
- \_\_\_\_\_, 1997. *Valuing Ground Water; Economic Concepts and Approaches*. National Academy Press, Washington, D.C.
- O'Neil, J. and C. Spash, 2000. Conceptions of value in environmental decision-making. *Environmental Values*, 9: 521-536.
- Pellezzoni, L., 1999. Reflexive Modernization and Beyond; Knowledge and Value in the Politics of Environment and Technology. *Theory, Culture & Society*, 16(4): 99-125.
- Reichelderfer, K. H., 1989. Externalities and the returns to agricultural research - discussion. *American Journal of Agricultural Economics*, 71(2): 464-465 .
- Setia, P. and R. Magleby, 1987. An economic analysis of agricultural nonpoint pollution control alternatives. *Journal of Soil and Water Conservation*, November-December: 427-431.
- Shortle, J. S., D. G. Abler and M. Ribaud, 2001. Agriculture and Water Quality: the Issues. In Shortle, J. S. and Abler, D. G. (ed.), *Environmental Policies for Agricultural Pollution Control*, CABI Publishing, New York.
- Simon, H. A., 1956. Rational choice and the structure of the environment, *Psychological Review*, 63: 129-138.
- \_\_\_\_\_, 1987. Bounded rationality. In Eatwall, J., M. Milgate and P. Newman, (ed.), *The New Palgrave A Dictionary of Economics*. MacMillan Press, London: 266-268.
- SOU, 1999. Jordbruk och miljönnytta (in Swedish), *Agriculture and environmental benefits*. Stockholm, Department of Agriculture.
- Stavins, Robert N., 1995. Transaction Costs and Markets for Pollution Control. *Resources (Resources for the Future)*, Spring 1995, 119: 9-10 and 18-20.
- Söderholm, P., 2001. The Deliberative Approach in Environmental Valuation. *Journal of Economic Issues*. 35(2): 487-495.
- Tietenberg, T., 2000. Tradable Permit Approaches to Pollution Control. In Kaplowitz, M.D. (ed.), *Property Rights, Economics, and the Environment*. JAI Press Inc., Stamford Connecticut.
- Trachtenberg, E. and C. Ogg, 1994. Potential for reducing nitrogen pollution through improved agronomic practices, *Water Resources Bulletin*, 30(6): 1109-1118.
- Tversky, A. and D. Kahneman, 1982. Judgment under uncertainty: Heuristics and biases. In Kahneman, D., P. Slovic and A. Tversky (ed.), *Judgment under uncertainty: Heuristics and biases*. Cambridge University Press, UK: 3-22.
- United States Environmental Protection Agency (EPA), 2000. *The Quality of Our Nation's Waters*. EPA-841-S-00-001, EPA/ Office of Water, Washington, DC.
- \_\_\_\_\_, 2003. *Final Water Quality Trading Policy*, EPA, Office of Water, <http://www.epa.gov/owow/watershed/trading/tradingpolicy.html>.
- \_\_\_\_\_, 1996. *Why Watersheds?* <http://www.epa.gov/OWOW/watershed/why.html>

- van den Bergh, C. J. M., A. Ferrer-i-Carbonell and G. Munda, 2000. Alternative models of individual behaviour and implications for environmental policy, *Ecological Economics*, 32: 43-61.
- VASTRA (Swedish Water Management Research Program), 1998. *Towards catchment-based strategies for sustainable resource use, 1998-2000*. February, 1998. <http://www.vastra.org>
- Wolf, A.T., 1995. Rural nonpoint source pollution control in Wisconsin: The limits of a voluntary program, *Water Resources Bulletin*, 31(6): 1009-1022.
- Woodward, R. T., Kaiser, R.A. and Wicks, A-M.B., 2002. The structure and practice of water quality trading markets. *Journal of the American Water Resources Association*, 38(4): 967-979.
- WWF -World Wide Fund for Nature (formerly World Wildlife Fund), 2001. *Elements of Good Practice in Integrated River Basin Management: A Practical Resource for implementing the EU Water Framework directive*. WWF, Brussels.