

Seed Coating for Delayed Germination
A Tool for Relay Cropping of Annual Crops

Fredrik Stendahl

Department of Ecology and Crop Production Science
Uppsala

Licentiate thesis
Swedish University of Agricultural Sciences
Uppsala 2005

Ecology and Crop Production Science • 6

*Department of Ecology and Crop Production Science
Swedish University of Agricultural Sciences
Uppsala 2005*

ISSN 1404-2347

Editor: Paula Persson

Abstract

Stendahl, F. 2005. Seed Coating for Delayed Germination. A tool for relay cropping of annual crops. Licentiate thesis.
ISSN 1404-2347

The diffuse leaching of plant nutrients from agricultural soils is part of the problem of the eutrophication of fresh water systems and coastal sea waters. Among the measures taken to reduce the leaching is keeping the soil with plant cover during autumn and winter. In areas with a predominance of annual crops this can be achieved by the undersowing of catch crops. In the current work it was investigated how the time of undersowing affected the barley (*Hordeum distichon* L.) crop and the catch crop biomass production. As catch crops Italian ryegrass (*Lolium multiflorum* L.), perennial ryegrass (*Lolium perenne* Lam.) and red clover (*Trifolium pratense* L.) were used. The biomass of the catch crop was markedly reduced with delayed undersowing, but net biomass production in late autumn was generally not affected. On light soil the barley yield was only to a small extent affected by the undersown catch crop, and with delayed undersowing the yield was even less affected. On heavier soil the barley yield was only marginally affected regardless of time of catch crop undersowing.

An alternative to the undersowing of catch crops would be relay cropping of two cereal crops, one spring crop and one winter crop. As their initial competitive capacities are similar there is a risk that the winter crop will affect the spring crop yield adversely. To be able to set the competitive relationship between the crops favourably for the relay cropping system to be effective, a means to delay the winter crop germination is needed. Delayed undersowing has the risk of damaging the spring crop by the drilling procedure itself, and this was also noticed in the catch crop field experiments. In a couple of experiments the technique of coating seeds with polymers to achieve delayed germination was explored. The materials used were cellulose lacquer (in one experiment with the addition of lanolin) or an acrylic plastic, a so called primer. Wheat (*Triticum aestivum* L.) and oil seed rape (*Brassica napus* L.) were coated in house with several coating levels and germinated under controlled conditions in Petri dishes. In one experiment the coated seeds were germinated under three different temperature levels and three different moisture levels.

It was found that delays could be achieved and that with increasing coating level the delays increased. It was also found that at low germination temperature (5.5 °C) for plastic coated seeds there was almost no difference in temperature sum needed from sowing to germination regardless of coating level. At high germination temperature (13.9 °C) there was a marked increase in temperature sum needed to germination and it increased with increasing coating level in comparison with uncoated seed. The resulting germination pattern was hypothetically explained by the dependence of water and oxygen uptake on temperature, in relation to the permeability of the coating materials. The permeability of the materials was probably rather constant over the temperature range. To gain the necessary control of the desired germination delay further investigations are needed, in collaboration with other scientific disciplines.

Key words: catch crop, undersowing, delayed germination, seed coating, relay cropping, plant nutrient leaching.

Author's address: Fredrik Stendahl, Gamla Landsvägen 29, SE-664 95 Borgvik, Sweden

Contents

Introduction, 7

Aim of study, 7

Background overview, 8

The general agroecological setting, 8

Germination of seeds, 9

Seed dormancy, 10

Relay cropping, 10

Managing germination and seed treatments, 11

Objectives, 13

Materials and methods, 13

In vivo (field) experiment, undersown catch crops. (Paper I), 13

In vitro experiments: coating and germination (Papers II and III), 14

General experimental set-up, 14

Seed coating techniques, 14

Pan coating equipment and coating, 15

Spinning disc coating equipment, 15

Spinning disc coating, 15

Seed, 16

Coating materials, 17

Acrylic plastic, 17

Cellulose lacquer, 17

Cellulose lacquer/lanolin mixture, 17

Germination equipment, 17

Germination substrate pore volume assessment, 18

Results and discussion, 19

In vivo (field) experiment, undersown catch crops, 19

In vitro experiments: coating and germination, 20

Concluding remarks, 23

References, 25

Acknowledgments, 27

Appendix

Papers I-III

This thesis is mainly based on the following papers that are referred to in the text by their Roman numerals

- I. Ohlander, L., Bergkvist, G., Stendahl, F. and Kvist, M. 1996. Yield of catch crops and spring barley as affected by time of undersowing. *Acta Agriculturae Scandinavica, Section B, Soil and Plant Science* 46, 161-168.
- II. Stendahl, F. Delayed germination of wheat coated with acrylic plastic and cellulose laquer. (manuscript)
- III. Stendahl, F. Delayed germination of rape seed coated with two water resistant materials germinated at three temperature levels and three moisture levels. (manuscript)

Paper I is reprinted with permission of the publisher.

Introduction

Aim of study

This work originates in agroecological research and discussions concerning the agricultural sustainability and environmental impact of current Scandinavian temperate agroecosystems. The main challenge underpinning this work is the diffuse nutrient leaching from arable land. Factors relevant to designing a cropping system with catch crops, to reduce the leaching, are explored. Further elaboration of such a system would be relay cropping practices with crops in current use. This hypothetical cropping practice aims at making it possible to sow two crops, one spring and one winter simultaneously in the same field. When the spring crop is harvested the winter crop will have an established stand with no autumn tillage necessary. The growing winter crop and the undisturbed soil will reduce the leaching of nutrients from the land as compared with both bare tilled soil and ordinarily sown autumn crops. To gain better control of the competitive relationship of the crops to be grown in relay, the additional technique of seed coating aimed at delayed germination, if reliably achieved, could be used. This work aims at giving increased knowledge about the feasibility of coating techniques for obtaining delayed germination in seeds.

The experiments conducted include experiments with undersown catch crops, Paper I, and two in vitro experiments exploring the coating of wheat kernels and rape seed to obtain delayed germination, Papers II and III. The predictability of the delayed germination of the coated seed is an important factor for further research into the proposed relay cropping system. The germination tests of the coated seed were done in Petri dishes under controlled temperature and moisture conditions.

There are some additional potential benefits to the suggested cropping practice, such as reduced soil compaction, increased crop stand competition against weeds, and reduced fuel consumption. Challenges are introduced as well, such as increased risk of the survival of pathogens from crop to crop, and vulnerability to pathogen attack on an early established winter crop. However, the underlying problem approached in the present work is that of nutrient leaching.

The study builds on and is part of the research regarding the agroecosystem approach to reducing nutrient leaching using catch crops carried out at the Department of Ecology and Crop Production Science at SLU, Uppsala, Sweden. Here, research regarding growth and competition in plant stands is of particular interest.

In the work underpinning Paper I, I participated in the execution of the field experiment as well as in the compilation of the results. I am the sole author of Papers II and III.

Background overview.

The general agroecological setting.

The diffuse leaching of plant nutrients from arable land has been identified as a substantial contributor to the eutrophication of fresh water systems and coastal sea waters. One reason for this is the increased specialization in agriculture leading in certain regions to larger coherent areas with cropping systems without ley and a subsequent predominance of annual crops, where the soil is tilled every year and frequently left without vegetation cover during the winter.

One further important factor relating to the nutrient emissions is the drainage of the cultivated landscape. In the last few centuries, large areas of previously waterlogged land have been drained to increase the area of land under cultivation, and the arable land itself has been extensively drained. This has resulted in much faster transport of water through the soil profile and through the whole landscape, reducing, for instance, exposure to uptake and denitrification of nitrogen.

Eutrophication of waterways and coastal seawaters causes an increase in algal plancton production. As the increased amount of organic matter sediments, its decomposition depletes the oxygen levels at sea bottom. The occurrence of low oxygen levels at the bottom of coastal sea basins can thus, in a chain of events, be linked to current agricultural practices: a large pool of plant nutrients in cycle and extensive drainage of the cultivated landscape in combination with tillage practices and in certain regions a predominance of annual crops, with the extra impact of high concentration of livestock in other regions (the latter leading to problems with the logistics of manure application in relation to growing crops, bare soil and precipitation).

Among the measures taken to reduce the diffuse leaching of plant nutrients are restoration of wetlands, use of catch crops, restrictions as to when manure can be applied, and recommendations regarding late autumn or spring tilling. There are also recommendations about increasing the cultivation of winter crops as a measure to keep the soil with a plant cover, albeit their capacity for nutrient uptake being weak. In short, all these measures either slow down the flow of water through the landscape, increase the area with plant cover during autumn and winter or reduce the mineralisation of organically bound nitrogen. These measures must, of course, be weighed against other factors to decide whether they are applicable or not, such as the negative effects of late autumn tillage on soils with clay which, when wet, are kneaded rather than tilled.

The subject of nutrient leaching, freshwater and sea eutrophication has been extensively researched. The above is a rough generalization to set the current work in perspective. The field of research is not without controversy. (Bergstrand, 1987; Rundquist & Andersson, 1987; Lindgren & Rasmuson, 1987; Rosenberg et al, 1990; Stålnacke, 1996; Jansson, 1997; Jansson *et al.*, 1998; Pihl *et al.*, 1999; Elmgren, 2001; Granstedt *et al.*, 2004; Håkansson *et al.*, 2005)

Germination of seeds.

The germination process of seeds can be described by discerning several different phases with regard to water uptake. The process can be divided into three phases, which overlap to some extent, see Figure 1 (Bewley & Black, 1994; Persson, 2005, personal comm.). Roughly the germination of seeds can be described as follows using the three phases of the figure. Phase 1 corresponds to initial imbibition and is mainly a physical process driven by the large difference in water potential of the dry seed and the available water of the germination substrate. Phase 2, the lag phase with no or little water uptake, corresponds to an initiation or activation of the physiological processes of the seed, eventually gaining a fully working metabolism. During this phase the physiological processes are activated and damage to cellular and sub-cellular structures are being repaired. The damage is caused by the dehydration and rehydration of the seed and by nonphysiological events (oxidation) occurring spontaneously during the period when the seed is in a desiccated state. Phase 3 corresponds to the emergence of roots and subsequent cellular elongation and renewal of water uptake. With emerging roots and subsequent shoot emergence from the seed, germination can be said to be complete.

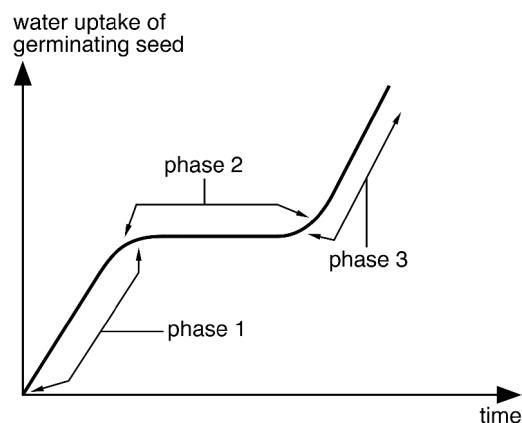

Figure 1. The three phases of a germinating seed in relation to water uptake: Phase 1, imbibition; Phase 2, the lag phase with initiated metabolism; Phase 3 with visible germination – emerging roots and shoot.

Phase 1 does not need oxygen since it is a physical process. Oxygen can in fact, in some cases, be detrimental owing to its high oxidizing capacity, and damage the cellular structures. During phase 2 when the metabolism of the seed is activated, oxygen is needed, and demand for it is increased, as it is essential to the metabolism. During phase 3 of germination and in further development, the full metabolic activity of the seed and the emerging structures require an increasing and continuous supply of oxygen.

Seed dormancy.

Many plant species have evolved the capacity to have seeds that do not germinate at once, but only after a period of dormancy. The time of dormancy of a specific seed in a seed lot could vary, so that not all seeds from a plant germinate simultaneously. This is an adaptation to ecological and climatological conditions. It enables the plant species to secure that some seeds do germinate when conditions for plant establishment are favourable. In agriculture, this capacity has been problematic for some crops, in that the plant stand establishment has been uneven when seeds in the seed lot do not germinate at the same time. Some seeds may even germinate during another growing season in a different crop, thus becoming a weed. In domesticated plant species selection has occurred in prehistorical agriculture, perhaps inadvertently, and in modern plant breeding by intent, towards cultivars that exhibit little if any capacity for dormancy.

As the problem of a large spread in germination is probably reintroduced, it is not easy, to induce a controlled seed dormancy for the purpose of delayed germination, either by activating secondary dormancy, or reintroducing primary dormancy in cereals by breeding.

Relay cropping.

Relay cropping can be defined as the interlaced cultivation of two crops in sequence, and is a kind of intercropping. The second crop is sown, or planted, in the first crop while it still is growing. Often the two crops grown in intercropping or relay utilize different niches of the ecological space. The leaves can be at different heights, have different shapes and/or the plants can have different requirements for light or nutrients. The roots of one crop can be shallow while the other crop has a deeper root system. The utilization of a certain ecological space can also be by a shift in time. In this way the potential output of a certain cultivated area can be more fully realized: the combined production from the intercropped area is larger than from the two crops grown separately under otherwise comparable conditions. (Vandermeer, 1989) Intercropping is a widespread type of cultivation in tropical and subtropical agroecosystems, but various forms of intercropping and relay cropping are also common in temperate agroecosystems.

Relay cropping is and has been extensively implemented in Scandinavia for a long time, in establishing leys. The seed of the ley, either sole cropping or species mixtures, is undersown in a spring cereal, such as barley or oats. At cereal harvest there are enough plants of the ley crop to later form a stand with sufficient plant cover. The cropping system with catch crops can also be said to be a relay cropping system. In Scandinavia the relay cropping of annual crops is uncommon today, and may not occur in practice at all. It is more common where the harvest of two crops per season is possible. There is ongoing research exploring the relevant factors to relay two cereal crops in Scandinavia, to which the current work is complementary (Huusela-Veistola & Känkänen, 2000; Roslon, 2003).

Managing germination and seed treatments.

The large field of seed treatment and seed coating has been reviewed by several authors, for instance Porter (1978), Eriksson (1982), Scott (1989), and has been the subject of symposia (Martin, 1988). Some examples of seed treatment, with the emphasis on coating follow below, with a few supplementary references.

There are several practices by which to manage germination. Many focus on helping the seed to germinate in a healthy and fertile environment. Seeds are treated with coatings, pelletings or other treatments, so that the emerging seedling is protected from pathogen attacks (Weiser et al, 1980), or so that the seed is able to germinate in waterlogged environments (e.g. Kojimoto *et al.*, 1989; Hwang & Sung, 1991) and/or with essential nutrients in close proximity. Seeds are also treated so that the establishment of the crop stand will be optimal for cropping and harvest methods, e.g. a seed that is very small or irregular in shape is coated with clay or some other bulk material to a form and size that is manageable for precision sowing machinery. Examples of this is the pelleting of sugar beet seed and small sized vegetable seed. There are treatments that are applied to seed so that the germination regulatory system within the seed are affected, to assure an even germination of the sown seed lot, such as the infusion of growth regulators via acetone (Persson, 1988, 1993). Seeds with hard seed coats can be scarified to ease the effort of the germinating embryo to emerge from the seed, see for instance Fulbright & Flenniken (1987).

Coatings with polymers are common, as biologically active substances, such as growth regulators or pesticides, can be mixed with the polymer and when applied be bound to the dried polymer coating. The polymer coating can often withstand handling reasonably well and the problem of dusting coating applications can be avoided. (Porter, 1978; Sauve & Shiel, 1980) The aim of all these efforts has been to produce a seed lot of the desired crop that germinates fast, evenly and with healthy seedlings.

In contrast, other treatments strive to delay the germination of the seed. The aim of most of these treatments is to help the seed to survive a period in soil when the germinating circumstances are poor, until the time when the seeds should germinate to establish a crop stand. For example: to sow seeds during autumn when sowing is practically possible, but in a way that ensures the seed will germinate in early spring when sowing is practically impossible, due to wet soil. During autumn and winter the seed should remain dry and metabolically inactive, since an imbibed seed or seedling is subject to chilling injuries, but as conditions change with the coming of spring, the seed should start to germinate. The early establishment of the crop made possible in this way gives the plants and the plant stand a significantly longer growing season and a consequently larger yield. This type of treatment has been investigated for agricultural crops as well as for forestry, with autumn direct seeding of pine, but actual practical applications have yet to be established (Pamuk, 2001), or are underway. Clayton et al., (2004) and Johnson *et al.*, (2004), explore practices where late to very late autumn sowing of uncoated and coated oil rape seed are compared. Germination

by sowing untreated seed in late winter, on frozen soil, has been explored by MacKey (1991). The difficulties of spring sowing and the possibilities of late autumn sowing have for a long time generated recurrent efforts, where much work has been invested in designing solutions for the delayed germination of the autumn sown crop, especially in Canada where the winters may be too severe for an ordinary winter crop. This is reflected in several patents for the production of coated seeds for delayed germination (for example: Schreiber & La Croix, 1970; Watts & Schreiber, 1974; Watts, 1976; Weiser *et al*, 1980; Langan & Christie, 1985). All of these efforts use polymers, to a greater or lesser extent hydrophobic or water resistant, by themselves or in conjunction with other materials, also with varying degrees of hydrophobicity, to achieve coatings that inhibit or reduce water uptake during imbibition. Most of the patents present summarized data of field experiments with seeds sown in autumn and an evaluation of seedling emergence in spring. The results presented show that with coatings a large emergence percentage can be achieved whereas uncoated seeds fail to produce seedlings in spring. Watts & Schreiber, (1974), report that the yield of autumn sown treated rape seed germinated in spring had a considerably larger yield than rape seed sown at the same rate at the normal time in spring. The time between the sowing in autumn and emergence varies roughly between 50 to 90 days. The length of the period where the applied seed coating actually has delayed the water uptake is hard to estimate, as the periods below 0 °C, where no water uptake takes place, are not presented. There was also no data with regard to how the delay of the germination of the coated seeds is correlated with temperature.

Kidd, (1995), describes a polymer coating material that is impermeable to water below a certain preset temperature. Above this temperature the polymer changes its structure to become permeable and seeds coated with the material can germinate. The material has gained use in enabling early sowing of maize (*Zea mays* L.), delaying the germination until soil temperatures are high enough to ensure that the germinating seed will not be exposed to chilling injuries. The use is mainly in the U.S.A in maize producing areas with cold springs. The temperature at which the coating is to become permeable can be set at the production of the polymer prior to coating.

Currently, the use of this material is also being promoted in facilitating the relay cropping of wheat (*Triticum aestivum* L.) and soya beans (*Glycine max* (L.) Merr.), where a double crop per growing season is possible (<http://www.intellicoat.com/relaycrop.asp>; 22-Apr-2005). The winter wheat is sown at large row spacing in autumn and before the wheat has jointed in mid spring the coated soybeans are sown between the rows of wheat. The coating treatment delays the germination of the soya beans long enough to ensure that the beans are not cut by the combine harvester at wheat harvest. This is the only material I have encountered in the literature that interacts with temperature. All other materials used with the aim of delaying germination by retarding imbibition appear to function by controlling the permeability rate, not by turning the permeability off and on. This is also the only example I have encountered where the concept of seed coating for delayed germination is used for the establishment of a relay cropping system.

Objectives.

The objective of the field experiments (Paper I) was to elaborate and evaluate a cropping practice where undersown catch crops would not reduce the yield of the main crop but still be vigorous enough in growth after the main crop harvest to ensure reduced nutrient leaching by taking up nutrients long into the autumn. The factors varied in the experiments were catch crop species, time of undersowing of catch crop with regard to crop development and fertilization levels. By varying the time of undersowing in order to set different competitive relationships between crop and catch crop we hoped to test the assumption that with an increased delay of catch crop undersowing, the crop yield reduction would lessen. The assumption that although the catch crop was undersown with a delay, it could still be able to perform as a nitrogen catcher in autumn, would also be tested.

The field experiments gave birth to the idea that instead of using a catch crop with the sole objective to retain the nutrients, it would perhaps be possible to undersow the next crop in a relay cropping system. One key factor would be to set the competitive relationship between the two crops. When two cereal crops are grown in relay with similar seed nutrient storage and initial growth patterns, the competitiveness between them would be strong (Håkansson, 2003). It seemed probable that a delay in the emergence of the undersown winter crop would be desirable in order to skew the competitive relationship in favour to the spring crop. To minimize, or avoid, the damage to an emerging spring crop of a delayed winter crop undersowing, a seed with a delayed germination could be sown simultaneously with the spring crop.

Thus a tool for delaying the germination of the crop to be undersown would be useful. The aim of the two *in vitro* experiments (Papers II and III) was to see if delayed germination could be achieved at all and with what predictability, by coating the tested seeds with materials that would impede the water uptake of the seed for some time. It was also of interest to see how the germination patterns of the coated seeds varied with temperature and moisture.

Materials and methods.

Below follows some general information on materials and methods used in the experiments presented in Papers I to III. Here are as well some supplementary descriptions of general interest.

In vivo (field) experiment, undersown catch crops. (Paper I).

Field experiments were carried out at two locations, Säby just outside Uppsala and Tönnersa south of Halmstad, during 3 consecutive years, 1988 to 1990. As catch crops Italian ryegrass (*Lolium multiflorum* L. cv. Svita), perennial ryegrass (*Lolium perenne* Lam. cv. Tove) and red clover (*Trifolium pratense* L. cv. Molly) were used and were undersown at four different stages of development of the main crop, two row spring barley (*Hordeum distichon* L.). The development

stages of the crop were specified using the decimal code (DC) (Zadoks *et al.*, 1974; Tottman, 1987; Åfors *et al.*, 1988). The four stages used as cues to undersow the catch crops were: DC00 (kernels still dry); DC05 (roots emerged from kernel); DC09 (first leaf at top of coleoptile); DC13 (three leaves fully developed). In the first two years two levels of nitrogen, 40 and 80 kg ha⁻¹, were applied and the last year only 80 kg ha⁻¹ was applied. Chemical weed control was carried out in all experiments. The experiments were designed as complete randomized block experiments with three replications. At harvest and late in autumn samples were cut by hand from an 0.5 m² area to estimate the amount of catch crop biomass at these times. Grain yield of barley was measured by combining a net area of 8.5 x 2.5 m².

In vitro experiments: coating and germination (Papers II and III).

General experimental set-up.

Two experiments were carried out exploring the coating of wheat kernels and rape seeds for delayed germination. The idea tested was the restriction of water uptake as a means of influencing the germination pattern of the treated seed. This led to the choice of cellulose lacquer (in one experiment with an added proportion of lanolin) and an acrylic plastic primer to be used as coating materials. The germination tests of the coated seed were performed in Petri dishes using Wettex cloth as germination substrate.

Germination readings of each Petri dish were made once every 24th hour during the 30 – 35 days that the experiments lasted. The experiment type was thus a repeated measures set-up, where each unit is examined repeatedly. The justification for using repeated measurements was an interest in following the specific germination behaviour of the seed sample/population in each Petri dish. And a need to avoid an experiment that would become too large to supervise if each measurement was to be made on a dish that would be discarded afterwards, in order to ensure the independence of the respective readings. A drawback of this latter approach would also be that the behaviour of one specific population could not be followed. The lack of independence was accounted for in the statistical analysis.

Moreover, a practical reason for not having one dish for each examination was that for some treatments the time elapsed between the first and the last germinated seed could be several days. Thus, if the germinated seeds were not removed as soon as they germinated, the roots of these seeds would spread throughout the dish and make later examinations difficult as well as being a target for mould growth. In combination this might have altered the moisture level in the dish, changing the conditions for the yet ungerminated kernels.

Seed coating techniques.

A custom built coating pan equipment (Figure 2) and an assembled spinning disc equipment (Figure 3) were used for coating the seed.

Pan coating equipment and coating.

The angle of the axle of rotation of the coating pan is set from 25° to 30°. The pan is set in motion at a speed that ensures that the seeds placed in the pan have a smooth, flowing motion. The coating is applied as a spray at short intervals until all seed surfaces look slightly moist. The enhanced air flow is applied so that the fluid used as solvent or as medium for an emulsion evaporates. The movement of the seeds ensures that all surfaces of the seeds are exposed to the coating as it is applied, and also reduces the risk that the seeds will stick to each other as the coating dries.

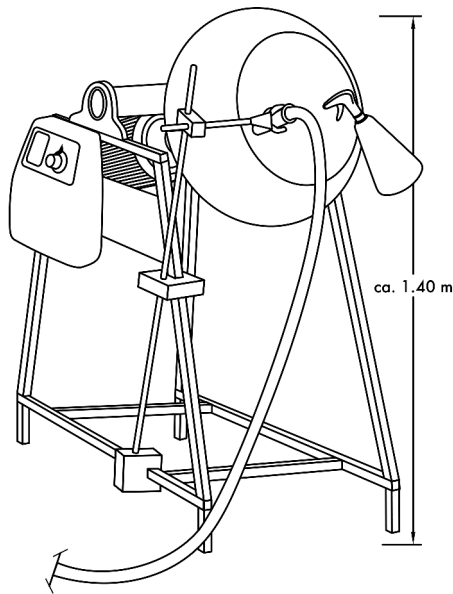

Figure 2. Schematic illustration of the coating pan equipment. The application of the coating material was done by hand using the hand held disperser. (Used in coating wheat kernels with acrylic plastic.)

Spinning disc coating equipment.

A custom spinning disc apparatus was assembled using a food processor, "Electrolux Assistent" with a cylindrical stainless steel bowl with a height of 17 cm and a diameter of 24 cm, a small electric motor with an axle and a 43 mm diameter disc attached at the end of the axle, which rotated at about 10 000 rpm. Regulated compressed air from two nozzles placed within the bowl was used to modify/enhance the seed movement during coating. Warm air from a hairdryer mounted on a stand was used to hasten the evaporation of coating material solvent or dilutant. A syringe with an injection needle was used to deliver the diluted coating material via the spinning disc to the seed during the coating procedure (Figure 3). (A slightly modified set-up was used in coating wheat kernels with lacquer, see Paper II.)

Spinning disc coating.

The rotating bowl sets the seed in motion, and, in the current apparatus set-up, the seed motion is enhanced by two nozzles attached opposite each other for regulated compressed air. The axle with the spinning disc is lowered into the

bowl. The disc spins at high speed. Drops of the solution with the dissolved coating material are positioned on the spinning disc using a syringe with an injection needle. By the strong centrifugal force, the applied drops are finely dispersed and thrown outwards towards the moving seed. The finely distributed small drops and the continuous motion of the seed make it, in principle, possible to obtain a uniform coating of the seed as the dilutant evaporates. The movement also reduces the risk of having the seeds stick together as the coating dries. If the speed is too high the flow of the movement becomes too agitated and some seeds may be ejected out of the bowl or the abrasive contacts between the seeds may become so intense that the applied coating is lost in patches. If the speed is too low, seeds may stick to each other as the applied coating solution dries.

The spinning disc technique is an established industrial technique and there is commercially available equipment. The equipment assembled and used for preparing the seed for the present study was sufficient to produce coatings of adequate quality.

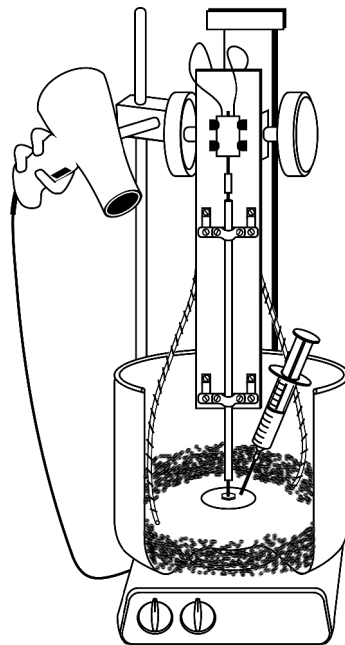

Figure 3. Assembled spinning disc equipment. The bowl has a cut-out in the illustration to show the placement of the disc, the two nozzles for compressed air and the seed lot being coated. The application of the coating material was done by hand using the syringe to put drops of material solution or emulsion onto the spinning disc. (Used in coating rape seed. See Paper III. A slightly modified version was used in coating wheat kernels with lacquer. See Paper II.)

Seed.

The seed used for the coating treatments was winter wheat (*Triticum aestivum* L. cv. Kosack), and winter rape (*Brassica napus* L. cv Express). Wheat was chosen as a crop that could be used in the hypothetical relay system. The rape seed was chosen as a model seed as the shape of the seeds is favourable for coating. The seeds/kernels were sifted prior to coating, so that their size was reasonably similar. This was to reduce the risk that an uneven size profile might result in

coatings of different thickness. Samples of 300 g of wheat kernels and 150-200 g of rape seed were treated per coating level.

Coating materials.

The rationale underpinning the choice of coating materials was the following: the mechanism to obtain the delayed germination was to delay the water uptake of the seed. After some trial and error it was found that cellulose lacquer (in one experiment with an added proportion of lanolin) and an acrylic latex primer, both available off the shelf at the local chemist's, were suitable for achieving a coating that would restrict the water uptake of the treated seeds. Moreover they were relatively easy to use in the coating process, and would serve well as model materials.

Acrylic plastic.

A commercial latex coating used to seal walls in e.g. bathrooms prior to tiling, a "primer", was used as one material. It is an acrylic latex coating, with a non-specified copolymer, manufactured by Beckers AB under the name "Resistent Spärrgrund". No further details of the formulation of the primer were available. Prior to use in the seed treatment procedure the coating was diluted with water with the proportion of one part coating and two parts water, and then gently stirred. Both the wheat kernels and the rape seed were coated with five different coating levels.

Cellulose lacquer.

A standard cellulose lacquer, "Alcroloid Polerlack", trademark of the company Alcro AB, was used as the second material in the wheat kernel experiment. As solvent a standard petroleum based dilutant was used, "Standardförtunning NT63", trademark of the company Beckers AB. Prior to use in the coating procedure the lacquer was diluted to suit the process. In the solution used, the amount of dry weight lacquer was estimated to be 10.1%. The wheat kernels were coated with five different coating levels.

Cellulose lacquer/lanolin mixture.

A mixture of cellulose lacquer "Alcroloid Polerlack", trademark of the company Alcro AB was used as the second material in the rape seed experiment. The proportions were 60% cellulose lacquer dry matter and 40% lanolin (fat extracted from sheep's wool). This proportion of lacquer/lanolin was chosen mainly for its coating properties: low tendency for the seeds to stick together during coating and a durable coating when dry. As solvent a standard petroleum based dilutant was used "Standardförtunning NT63", trademark of Beckers AB. In the prepared solution there was 1 part of dry matter lacquer/lanolin and 3.5 parts solvent by weight. The rape seed was coated with five different coating levels.

Germination equipment.

The seeds were germinated in plastic Petri dishes, 90 mm in diameter. Filter paper was ruled out as a substrate since it dries fast, moulds after some weeks,

and tears if handled when moist. Germinating the seeds in soil or sand, a possibility that comes to mind naturally, makes it difficult to observe the seed during germination. Since the seed population in each Petri dish was to be observed once every 24th hour for 30-35 days, soil was therefore impractical.

The chosen substrate was "Wettex", a cloth consisting mainly of cellulose fiber mixed with cotton fiber, produced by Freudenburg Household Products AB. This is used for cleaning, but it is also used in plant nurseries for growing seedlings. It has good water retention capacity. Round pieces of cloth were cut to fit into the Petri dishes. Three pieces of cloth were placed in each Petri dish and moistened with water. The dishes were sealed along the rim with broad rubber bands, to reduce the risk of losing water by evaporation. In this way constant moisture conditions were ensured throughout the experiment. (Figure 4.)

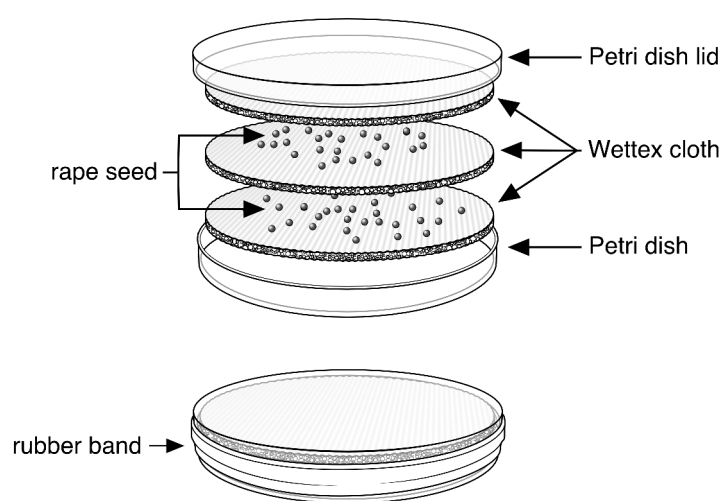

Figure 4. The illustration shows the placement of Wettex cloth substrate and seeds in the Petri dishes and the sealing of the dish with a rubber band.

The germinations were carried out in standard refrigerators and a constant room. The temperatures were monitored by Orion Components Ltd miniature temperature logger "TINYtalk" with samples taken at intervals throughout the germination tests. For the rape seed germination test the actual temperature means based on the sample values were 5.5, 7.8 and 13.9 °C with standard deviations of 0.87, 1.07 and 0.63, respectively.

Germination substrate pore volume assessment.

The Wettex cloth total pore volume was determined to ensure that the moisture levels in the Petri dishes could be reliably established. Each Petri dish had room for three pieces/layers of moist Wettex cloth. The cloth was cut into round pieces that fitted the dishes. Prior to use, the cut pieces were boiled and rinsed so that the cloth shrank to a fixed size and possible residues of chemicals that may have been left in the cloth from the manufacturing process were rinsed out.

The maximum volume of water that the three cut pieces of cloth could hold was determined, and this value was used as an estimate of the total cloth pore volume. Samples of dry cloth, three by three, were weighed and their compound weights were noted. Then the three pieces of cloth were stacked together on top of a net placed on a stand so that excess water could drop onto an empty plate below. Water was added on top of the stack until one drop of excess water dropped to the plate. The volume of water added was noted. This was replicated twelve times. Per replica the volume of water added per weight Wettex cloth was calculated as was, subsequently, the mean of volume water per weight cloth. The reason for determining the joint capacity of the three pieces together and not one by one, was that the amount of water held by the stacked pieces might be different from the amount held by the single pieces. As the germination test used three stacked pieces, it was considered more consistent to determine the water retention capacity in a way that resembled the experimental set-up.

The value obtained was used as an estimate of the total pore volume per weight of cloth. By filling part of the estimated total pore volume with water the cloth would hold different levels of moisture. The volumes of water added to the cloth to obtain the different moisture levels used in the experiment were 25%, 50%, and 75% of the estimated total pore volume.

In preparing the Petri dishes for sowing, the cloth for each dish was weighed. Then the amount of water added to each dish was calculated using the pore volume per weight estimate and the moisture level percentage. The estimated total pore volume was 15.12 milliliters per gram of Wettex cloth, with a standard deviation of 0.42 over the twelve replications. It was not necessary to re-moisten the cloth during the run of each experiment.

Results and discussion.

In vivo (field) experiment, undersown catch crops.

The results from the field experiments show that a substantial growth of the catch crop during autumn is possible although the amount of catch crop is low at crop harvest. The catch crop can be held back substantially by the spring crop and still have enough surviving plants after crop harvest to generate a strong growth in autumn. Perennial ryegrass, grown on the heavier soil at Säby, sown at DC09 or DC13, averaged over the years, had a production of 69 and 27 kg dry matter ha⁻¹ at barley harvest. In late autumn the net production had reached 1 044 and 569 kg dry matter ha⁻¹ respectively. The corresponding values for catch crops sown at the same time as the barley crop, at DC00, was 307 kg dry matter ha⁻¹ at barley harvest and 1 076 kg dry matter ha⁻¹ net production at late autumn. The relationships at Tönnersa were similar. It was concluded that the amount of catch crop at main crop harvest is only of moderate importance for the net growth in autumn. This is in conformity with the relationships between a cereal crop and weeds described by Håkansson (2003), where with increasing main crop competitiveness there is a relatively larger reduction of weight of weeds than in the reduction of number of surviving plants (Figure 5).

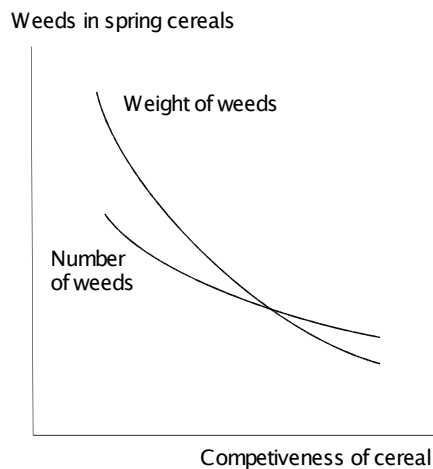

Figure 5. The general relationship between competitiveness of a cereal crop and weed weight and number of weed plants. Instead of “weed” it would be possible to have “catch crop” in the figure text to illustrate the results of the field experiments. The increase in competitiveness of the cereal is here accomplished by a delayed undersowing of the catch crop. Modified after Håkansson, (2003).

The barley crop is a strong competitor and yield was only marginally reduced by the catch crop, but still slightly more at Tönnersa than at Säby. The reductions were not significant. With the more heavy soil at Säby the time of undersowing gave no effect, while with the lighter soil at Tönnersa a delayed undersowing gave less reduction in yield. With increased delay of undersowing there was a marked decrease in catch crop dry matter at main crop harvest.

These results of the field experiments led us to discuss the possibilities of undersowing a winter crop directly instead of a catch crop. We had seen that as long as there were enough surviving plants of the undersown crop after spring crop harvest there would be a substantial growth in autumn. If a cereal crop was to be undersown, such as winter wheat, a crop with similar initial competitive capacity, we concluded that it would probably be needed to delay the winter crop emergence at least to DC09 of the spring crop and probably longer. A problem would be that delayed undersowing at stages later than DC09 of the spring crop would damage the spring crop too much by the drilling procedure itself. In the field experiments there were tendencies to such damage, reducing the yield of the spring crop. This was also noted by Kvist (1992).

With these experiences and our knowledge of plant stand establishment, the need for a means to delay the germination of the winter crop emerged. The winter crop could then be sown simultaneously with the spring crop and germinate later. The length of the delay should be possible to adjust so that an appropriate competitive relationship between the spring crop and the winter crop could be achieved. Thus the work on the seed coating and germination experiments, presented in papers II and III, was started.

In vitro experiments: coating and germination

The wheat kernels coated with acrylic plastic gave, with increased coating level, an increased delay (Paper I). With increasing coating level there was also an

increased spread in time between germination to at least 5% and to at least 65%. The relative delay in germination to at least 65% was approximately for coating level 1.) 6 days, for coating level 2.) 12 days and for coating level 3.) 27 days. The spread between time to at least 5% germination and to at least 65% was approximately for coating level 1.) 4 days, for coating level 2.) 7 days and for coating level 3.) 12 days. In coating level 4 only few kernels germinated soundly and in coating level 5 no kernels germinated. The coatings were either too tough for the roots or shoot to penetrate, and/or were also too restrictive to gaseous exchange thereby causing damage to the seed metabolism. The wheat kernels coated with cellulose lacquer had almost no germination delay regardless of coating level. Coating levels 4 and 5 had a relative delay of approximately 2 days. The wheat kernels were germinated at approximately 9 °C.

It was thus shown that a delay could, at least using the acrylic plastic, be achieved. The spread in time between certain percentage levels of germination can probably be attributed an inherent characteristic of the coating method used. The thicker the coating the more uneven it is prone to become. The wheat kernels were difficult to coat due to their form. The longitudinal crease and the tusk of epidermal hairs at the top made an even and complete coating hard to achieve. The plastic was easier to use than the lacquer, and was thus, evidently, applied too heavily as the two highest coating levels failed to germinate properly.

To further explore the germination behaviour of coated seeds the next experiment (Paper III) used rape seeds, which were easier to coat, and which were germinated under different temperature and moisture levels. The germination data was presented in relation to temperature sum as this eliminated differences caused by the different germination temperatures. Uncoated seed germinated at a temperature sum of approximately 20 day degrees °C regardless of germination temperature (base temperature 3.13 °C).

The statistical analysis revealed several significant interactions. The germination patterns of the coated seed were that with increased coating level and increased germination temperature there was an increase in temperature sum needed from sowing to at least 65% germination. With increasing coating level and increased germination temperature there was also an increase in the temperature sum span between at least 5% germinated seed to at least 65% germinated seeds. At low germination temperature there was almost no influence in temperature sum needed from sowing to germination for seeds coated with acrylic plastic, regardless of coating level. For lacquer/lanolin coated seeds outcome was similar, although there was a slight influence of the higher level coatings. For the plastic coated seeds this meant that at low germination temperature the seeds germinated almost at the same time as uncoated seeds regardless of coating level. For seeds germinated at higher temperature, there was substantial delay for coated seeds, increasing with coating level. For the lacquer coated seeds, there was a delay time in germination for the higher level coatings also at low germination temperature.

There was no interaction with moisture levels. The probable cause for this was that the water potential was close to zero for all moisture levels, and water was thus freely available for the germinating seeds.

Apart from the more technical aspects of the seed coating and choice of coating materials the results of interest, from an agronomic point of view, of the germination experiments can tentatively be summed up in a generalized figure (Figure 6.). The uptake of water (and oxygen) per unit time increases with temperature. For the sake of the generalized argument this is represented here by a straight line, although if measured it is probably a sigmoid formed curve over a broader temperature interval. In the temperature interval of practical interest here, it can probably be approximated to a straight line without compromising the argument. The dependence of uptake per unit time on temperature is strong for the germinating seed. For the coating materials used it seems that the permeability is fairly constant throughout the temperature interval. This is a hypothesis, as the permeability of the materials has not been measured, but appears to be in conformity with the results. The slight inclination of the lines representing the permeability per unit time of the coating materials is based on the assumption that the viscosity of water is high at low temperatures and will thus permeate at a slightly lower rate than at higher temperatures.

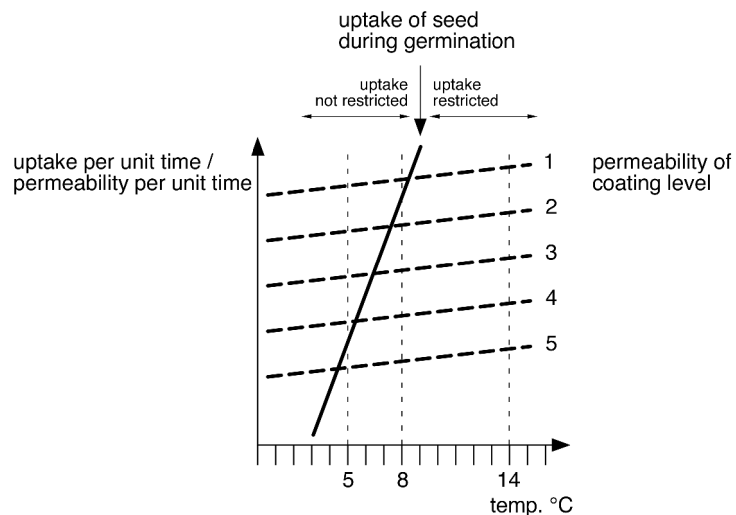

Figure 6. The generalized outcome of the germination experiment set-up as a relationship between uptake or permeability per unit time versus temperature. The inclination of the permeability of the coating material is hypothetical, but is based on the assumption that the water at lower temperature has a higher viscosity and thus permeates at a lower rate than at higher temperatures. (The figure generalizes mainly the germination outcome of rape seed coated with acrylic plastic, Paper III.)

At low germination temperature only level 5 coatings are slightly restricted. The permeabilities of the other coating levels are not restrictive for the water uptake of the germinating seed. For a more intermediate germination temperature

all coating levels except level 1 restricted water (and probably oxygen) uptake for the germinating seed and caused an increasingly delayed germination with increasing coating level. At high germination temperature all coating levels restricted uptake. Thus, for seed germinating at low temperature this means that regardless of coating level, all seeds will germinate at the same time as uncoated seed, except seeds with coating level 5 that will be slightly delayed.

The ideal relationship between the rate of uptake of the germinating seed and the permeability of a coating material can be generalized as in Figure 7. Depending on coating thickness and regardless of germination temperature, the restraint of the coating material to seed water uptake should be the same. Thus with regard to the aim of setting a specific level of the competitive relationship between crop A and crop B, it would be a question of choosing the appropriate coating thickness.

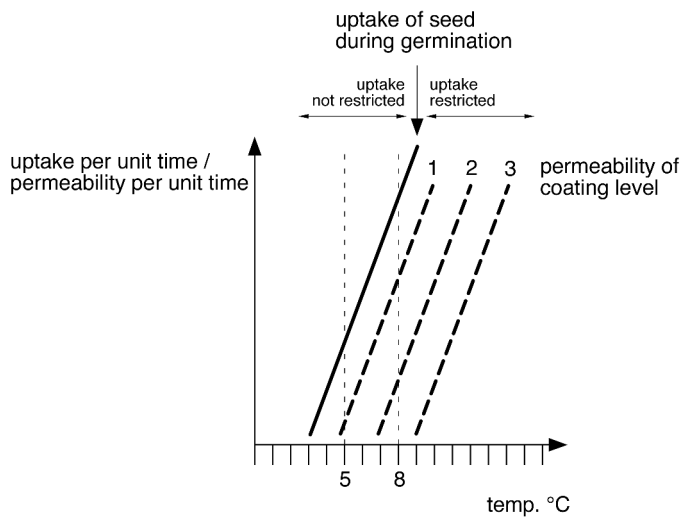

Figure 7. The generalized relationship between uptake and permeability versus temperature with a hypothetical coating material, fulfilling the criteria of a material where the permeability has a constant relationship to the seed water uptake regardless of germination temperature.

Concluding remarks

A specification of the properties of an ideal material can now be made. The specifications, with regard to the agronomic focus of controlling germination, of the ideal material are these: 1.) The material should have a permeability to water per unit time corresponding to a certain factor of the uptake of water per unit time of the germinating seed during imbibition regardless of ambient temperature; or alternatively, the material should be completely resistant to water until a certain temperature sum is reached, at which point the material should lose its water resistance. 2.) the material should be brittle enough to craze (as in the description of ceramic glazes) at seed swelling during phase 1, imbibition, of

the seed germination so as not to restrict oxygen uptake during phases 2 and 3, since this could be detrimental to the vitality of the emerging seedling.

Further aspects of the characteristics of the material are that the material, or the procedure by which it is applied, should be non-toxic to the seed, and, obviously, that it should be readily biodegradable into non-toxic compounds. The development or formulation of such a material is beyond the scope of agronomic science and requires efforts from material and surface sciences and engineering. Efforts to estimate actual permeability and to theoretically model permeability of seed coating or pelleting materials have been made (see e.g. Schneider & Renault, 1997; Grellier *et al.*, 1999) with main focus on delivering tools by which this can be explored.

It has to be borne in mind that the ultimate reason for performing these coating exercises was a desire to elaborate a procedure by which the level of the competitive relation, between spring crop A and winter crop B to be grown in relay, could easily and reliably be set. By having the seed of the winter crop coated and having the seed-lots of the two crops mixed in the seed drill, the crops could be sown simultaneously, preferably with a seed drill that spread the seeds laterally. Crops for two years could then be sown on the same occasion, reducing the need for at least some extra driving on the soil. The risk of damaging crop A at undersowing of uncoated seeds of crop B on a later occasion would be avoided. The damage to crop A at undersowing of crop B on a later occasion has been experienced in several field experiments, see for instance Paper I, Kvist (1992) and Roslon (2003).

A further step to coat seeds for delayed germination would be to delay the germination to late summer, early autumn, when the leaves of the spring crop are withering and light can anew reach soil surface through the plant stand. This type of coating, over the summer season would probably need to have a built-in time set mechanism for decay. The material should be completely impermeable for at least three months. During informal discussions at the Department of Fibre and Polymer Technology at the Royal Institute of Technology (KTH) in Stockholm, this type of mechanism was presented as in principle possible to achieve. The Canadian experiences cited above with coating seeds to be sown in autumn and to germinate in spring relate to a different context with long periods of temperatures below 0 °C.

Nonetheless, the coating of seeds to obtain a tool to delay germination in a predictable way should, when eventually achieved, be used in conjunction with all current knowledge, experience and tools available to set the competitive relationship between the two crops to be grown in relay. Focus is to be kept on the main issue — an, in the long term, sustainable relationship between the agroecosystems and surrounding ecosystems.

References

- Åfors, M., Ohlander, L. and Stendahl, F. 1988. Stråsådens utveckling. *Växtodling 1*. Department of Crop Production Science, Swedish University of Agricultural Sciences.
- Bergstrand, E., Jonsson, P., Eriksson, G., Jansson, B., Nyström, E., m. fl. 1987. Miljö kvalitet i haven runt Sverige, Del 1. Bakgrundsmaterial till "Aktionsplan mot havsföroreningar". *Naturvårdsverket Rapport 3320*.
- Bewley, J. D. and Black, M. 1994. *Seeds. Physiology of development and germination*. 2nd ed.. Plenum Press, New York and London.
- Clayton, G. W., Harker, K. N., O'Donovan, J. T., Blackshaw, R. E., Dossall, Stevenson, F. C., Johnson, E. N. and Ferguson, T. 2004. Polymer seed coating of early- and late-fall-seeded herbicide-tolerant canola (*Brassica napus* L.) cultivars. *Canadian Journal of Plant Science 84*, 971-979.
- Elmgren, R. 2001. Understanding Human Impact on the Baltic Ecosystem: Changing Views in Recent Decades. *Ambio 4-5*, 222-231.
- Eriksson, 1982: Eriksson, L., Litteraturstudie inom området fröbehandlingar, speciellt avseende pålagda skikt med bl a vattenkvarhållande förmåga. The Swedish Institute of Surface Chemistry, Box 5607, Stockholm. STU dnr 81-5634, 1982
- Fulbright, T. E. and Flenniken, K. S. 1987. Temperature and Scarification Effects on Germination of Prostrate Bundleflower Seeds. *Journal of Range Management 2*, 170-173.
- Granstedt, A., Seuri, P. and Thomsson, O. 2004. Effective recycling agriculture around the Baltic Sea. Background report. *Ekologiskt lantbruk 41*. Centrum för uthålligt lantbruk (CUL).
- Grellier, P., Riviere, L. M. and Renault, P. 1999. Transfer and water-retention properties of seed-pelleting materials. *European Journal of Agronomy 10*, 57-65.
- Huusela-Veistola, E. and Känkänen, E. 2000. Relay intercropping of cereals in Finland: Prospects and problems, in Farming systems for the new millenium eds. Cook, S. K., Cormack, W. F., Green, M., Holland, J. M., Leake, A. R. and Welsh, J. P. *Aspects of Applied Biology 62*, 95-100.
- Hwang, W. D. and Sung, F. J. M. 1991. Prevention of soaking injury in edible soybean seeds by ethyl cellulose coating. *Seed Science and Technology 19*, 269-278.
- Håkansson, L., Karlsson, M., Malmaeus, M., Pettersson, K., Rydberg, K., Stigebrandt, A. and Walin, G. 2005. Regeringens miljöexperter ansvariga för Östersjöns kris. *Dagens Nyheter, onsdag 20 april*, p6.
- Håkansson, S 2003. *Weeds and Weed Management on Arable Land. An Ecological Approach*. CABI Publishing. Wallingford and Camebridge
- Jansson, B-O. 1997. The Baltic Sea: Current and Future Status and Impact of Agriculture. *Ambio 7*, 424-430.
- Jansson, Å., Folke, C. and Langaas, S. 1998. Quantifying the nitrogen retention capacity of natural wetlands in the large-scale drainage basin of the Baltic Sea. *Landscape Ecology 13*, 249-262.
- Jonhson, E. N., Miller, P. R., Blackshaw, R. E., Gan, Y., Harker, K. N., Clayton, G. W., Kephart, K. D., Wichman, D. M., Topinka, K. & Kirkland, K. J. 2004. Seeding date and polymer seed coating effects on plant establishment and yield of fall seeded canola in the Northern Great Plains. *Canadian Journal of Plant Science 84*, 955-963.
- Kidd, G. 1995. Wrapping seeds increase yields and lower losses. *Biotechnology 13*, 937-939.
- Kojimoto, S., Nii, F. and Mori, T. 1989. Coated Seeds. *United States Patent*, no. 4,802,305, 1-3.
- Kvist, M. 1992. Catch crops undersown in spring barley - competitive effects and cropping methods. *Crop Production Science 15*. Department of Crop Production Science, Swedish University of Agricultural Sciences.
- Langan, E. C. and Christie, H. W. 1985. Seed coating composition and method. *United States Patent*, no. 4,493,162, 1-4.

- Lindgren, Rasmuson. 1987. Åtgärder inom Kommuner och Industrier. Del 3. Bakgrundsmaterial till "Aktionsplan för havsföroreningar". *Naturvårdsverket Rapport 3322*.
- MacKey, J. 1991. Försök med sådd av höstsäd på frusen mark under senvintern. *Sveriges Utsädesförenings tidskrift 101*, 198-202.
- Martin, t. 1988. . Application to Seeds and Soil.
- Pamuk, S. G. 2001. Seed coating of Scots pine (*Pinus Sylvestris* L.) to enable autumn direct seeding. *Reports 49*. Department of Silviculture, Swedish University of Agricultural Sciences.
- Persson, B. 1988. Enhancement of seed germination by plant growth regulators infused via acetone. *Seed Science and Technology 16*, 391-404.
- Persson, B. 1993. Enhancement of seed germination in ornamental plants by growth regulators infused via acetone. *Seed Science and Technology 21*, 281-290.
- Pihl, L., Svenson, A., Moksnes, P-O. and Wennhage, H. 1999. Distribution of algal mats throughout shallow soft bottoms of the Swedish Skagerrak archipelago in relation to nutrient sources and wave exposure. *Journal of Sea Research 41*, 281-294.
- Porter, F. E. 1978. Coat seeds with polymers. *Chemical Technology 8*, 284-287.
- Rosenberg, R., Elmgren, R., Fleischer, S., Jonsson, P., Persson, G. and Dahlin, H 1990. Maine Eutrophication Case Studies in Sweden. *Ambio 3*, 102-108.
- Roslon, E. 2003. Relay Cropping of Spring Barley and Winter Wheat. *Agraria 427*. Department of Ecology and Crop Production Science, Swedish University of Agricultural Sciences.
- Rundquist, B. and Andersson, R. 1987. Åtgärder inom jordbruket. Del 2. Bakgrundsmaterial till "Aktionsplan mot havsföroreningar". *Naturvårdsverket Rapport 3321*.
- Sauve, E. M. and Shiel, R. S. 1980. Coating seeds with polyvinyl resins. *Journal of Horticultural Science 4*, 371-373.
- Schneider, A. and Renault, P. 1997. Effects of Coating on Seed Imbibition: I. Model Estimates of Water Transport Coefficient. *Crop Science 37*, 1841-1849.
- Schreiber, K. and La Croix, L. J. 1970. Manufacture of dormant pelleted seeds. *United States Patent*, no. 3,545,129, 1-7.
- Scott, J. M. 1989. Seed Coatings and Treatments and Their Effects on Plant Establishment. *Advances in Agronomy 42*, 43-83.
- Stålnacke, P. 1996. Nutrient loads to the Baltic sea. *Linköping Studies in Art and Science. 146*, Theme of Wate and Environmental Studies, Linköping University.
- Tottman, D. R. 1987. The decimal code for teh growth stages of cereals, with illustrations. *Annals of Applied Biology 110*, 441-454.
- Vandermeer, J. 1989. *The ecology of intercropping*. Cambridge University Press. Camebridge
- Watts, H. 1976. Method of coating seeds to control germination and the resultant coated seeds. *United States Patent*, no. 3,947,996, 1-4.
- Watts, H. and Schreiber, K. 1974. Manufacture of dormant pellet seed. *United States Patent*, no. 3,803,761, 1-3.
- Wieser, F., Rückl, G. and Hofinger, H-P. 1980. Coating of plant seeds and composition used in this process. *European Patent Application*, publication nr. 0 010 630, 1-13.
- Zadoks, J. C., Chang, T. T. and Konzak, C. F. 1974. A decimal code for the growth stages of cereals. *Weed Research 14*, 415-421.

WEB pages

Landec Ag – Intellicoat, <http://www.intellicoat.com/relaycrop.asp> (accessed 22-Apr-2005).

Acknowledgments

I thank Sten Ebbersten and Lars Ohlander for the continuous support and advice, Gunnar Ekbohm for advice on the statistics and for all supportive discussions, and Lars Andersson for comments on the manuscript. I also thank Bertil Persson for valuable advice and guidance concerning the germination of seeds, and Magnus Halling for the repeated help with the execution of the statistical analysis.

I thank Christina Stendahl and Linda Schenck for scrutinizing the English of the manuscripts.

Last but not least, I deeply thank my closest family, my extended family and my friends for all the support and all the encouragement I have received over the years.

